



Product Catalog

Series R Helical Rotary Liquid Chillers

80 to 250 Nominal Tons Model RTWD Water-Cooled

80 to 250 Nominal Tons Model RTUD Condenserless

Made in USA (60 Hz)





Introduction

To meet a wide range of applications in the 75-240 ton water-cooled market, Trane is proud to introduce the model RTWD helical-rotary liquid chiller. To meet a wide range of applications in the 70-200 ton condenserless market, Trane is offering the RTUD condenserless chiller. The introduction of this next-generation chiller is an exciting step forward in application versatility, ease of installation, control precision, reliability, energy-efficiency, and operational cost-effectiveness. The new chiller is designed to deliver proven Series R performance, plus all the benefits of an advanced heat transfer design with two low-speed, direct-drive compressors.

Important Design Advances and New Features

- Higher full-load energy efficiency that meets ASHRAE 90.1 and reduces both operating and life-cycle costs.
- Variable evaporator flow compensation for improved control stability with energy saving variable flow applications.
- Single chiller time of day scheduling communication option for easier control of small jobs.
- Dual independent refrigerant circuits.
- HFC-134a optimized design.

The industrial-grade design of the Series R helical-rotary chiller is ideal for both industrial and commercial markets, in applications such as office buildings, hospitals, schools, retail buildings, and industrial facilities. The reliable compressors, wide operating temperature range, advanced controls, electronic expansion valve, short anti-recycle timers, and industry-leading efficiencies mean that this latest Trane Series R chiller is the perfect choice for tight temperature control in almost any application temperatures, and under widely varying loads.

Copyright

This document and the information in it are the property of Trane, and may not be used or reproduced in whole or in part without written permission. Trane reserves the right to revise this publication at any time, and to make changes to its content without obligation to notify any person of such revision or change.

Trademarks

All trademarks referenced in this document are the trademarks of their respective owners.

Revision History

RLC-PRC029G-EN (27 Jul 2015)

- Added marine waterbox option.
- Updated customer wiring tables.



Table of Contents

Table of Contents	3
Features and Benefits	4
Application Considerations	7
Model Number Descriptions	11
General Data	13
Performance Data	21
Controls	35
Electrical Data	39
Electrical Connection	64
Dimensions	72
Weights	80
Mechanical Specifications	82



Features and Benefits

Reliability

- The Trane helical rotary compressor is a proven design resulting from years of research and thousands of test hours, including extensive testing under extraordinarily severe operating conditions.
- Trane is the world's largest manufacturer of large helical rotary compressors, with more than 240,000 compressors installed worldwide.
- Direct drive, low-speed compressors—a simple design with only four moving parts—provides maximum efficiency, high reliability, and low maintenance requirements.
- Suction gas-cooled motor stays at a uniformly low temperature for long motor life.
- Electronic expansion valve, with fewer moving parts than alternative valve designs, provides highly reliable operation.

High Performance

- Advanced design enables chilled water temperature control to $\pm 0.5^{\circ}\text{F}$ (0.28°C) for flow changes up to 10 percent per minute, plus handling of flow changes up to 30 percent per minute for variable flow applications.
- Two minute stop-to-start and five minute start-to-start anti-recycle timer allows tight chilled water temperature control in constant or transient low-load applications.
- High compressor lift capabilities for use with heat recovery and waterside heat pump applications allows highly efficient system design with minimal operational concerns.
- Tight water temperature control extends to operation of multiple chillers in parallel or series configurations, offering further system design flexibility for maximum efficiency.
- Optional LonTalk/Tracer Summit communications interface provides excellent, trouble-free inter operability.

Life Cycle Cost-Effectiveness

- Precise compressor rotor tip clearance ensures optimal efficiency.
- Condenser and evaporator tubes use the latest heat transfer technology for increased efficiency.
- Electronic expansion valve enables exceptionally tight temperature control and extremely low superheat, resulting in more efficient full-load and part-load operation than previously available.
- Chilled water reset based on return water temperature is standard.
- Electrical current-limiting is available as an option.

Application Versatility

- **Industrial/low temperature process cooling** – Excellent operating temperature range and precise control capabilities enable tight control with single chiller or series configuration.
- **Ice/thermal storage** – Specifiers and operators benefit from dual setpoint control and industry-leading temperature, efficiency, and control capabilities, plus outstanding support through partnership with Calmac, a strong Trane partner providing proven installation examples, templates, and references that minimize design time and energy costs.
- **Heat recovery** – Maximum condenser temperature exceeds those of previous technologies, providing hot water and tight control that minimizes operating costs for the chilled water plant and boiler/hot water heater, while also providing consistent dehumidification.

- **Water to water heat pump** – For multi-chiller systems where there is a base or year-round heating load the RTWD can be used as a water side heat pump by utilizing ground or surface water as a heat source. Leaving condenser temperature control option allows for the chiller to be used and controlled primarily for the heat produced in the condenser.
- **Dry Cooler** – Allows for use with a closed condenser loop system that minimizes the potential for cross-contamination of the condenser loop.
- **Variable primary flow** – Variable evaporator flow compensation allows multi-chiller systems to vary the flow of water throughout the entire system (from the evaporator through the cooling coils). This feature also provides additional system efficiency as the number of pumps and the flow rate in the system are reduced. Standard 2 pass or optional 3 pass evaporator allows for a wider range of flow capabilities.
- **Series chiller configuration** – For two-chiller systems all the system water passes through the evaporators and/or condensers of both chillers to take advantage of system efficiency gains due to thermodynamic staging as well as downsizing the upstream chiller.
- **EarthWise system** – Low flow and high temperature differential installations allow for reduced pump and cooling-tower energy by decreasing the amount of water flow pumped through the system. This results in downsizing of all HVAC and ancillary equipment which provides installation and operational savings.

Simple, Economical Installation

- All units fit through standard double-width doors and most units fit through single width doors. Units are designed with bolt-together construction for disassembly to fit through smaller openings.
- Small footprint saves valuable equipment room space and alleviates access concerns for most retrofit jobs.
- Lightweight design simplifies rigging requirements, further reducing installation time requirements and costs.
- Full factory refrigerant and oil charges reduce required field labor, materials, and installation cost (RTWD). An optional nitrogen charge can reduce the time and labor for projects expecting dis-assembly.
- Optional integrated forklift channels on the unit base allow for easy movement of the chiller at the job site.
- Single or dual point power connection options simplify overall installation.
- Unit-mounted starter eliminates additional job site installation considerations and labor requirements.
- Trane CH530 controls easily interface with Tracer Summit™, or LonTalk™, or BACnet™ building automation systems through single twisted-pair wire.
- Trane has conducted extensive factory testing during manufacturing, and also offers options for in-person and/or documented system performance verification.

Precision Control

- Microprocessor-based Trane CH530 controls monitor and maintain optimal operation of the chiller and its associated sensors, actuators, relays, and switches, all of which are factory-assembled and extensively tested.
- Easy interface with computers hosting LonTalk/Tracer Summit/BACnet building automation/energy management systems allows the operator to efficiently optimize comfort system performance and minimize operating costs.
- Proportional Integral Derivative (PID) control strategy ensures stable, efficient chilled water temperature, maintaining $\pm 1^{\circ}\text{F}$ (0.56°C) by reacting to instantaneous load changes.
- Adaptive Control™ attempts to maintain chiller operation under adverse conditions, when many other chillers might simply shut down. This is accomplished by unloading the compressor due to high condensing pressure, low suction pressure and/or overcurrent.
- EMC certification ensures trouble-free use of electronic devices around the chiller.
- Easy-to-use operator interface displays all operating and safety messages, with complete diagnostics information, on a easily readable panel with a scrolling touch-screen display.
- New variable evaporator flow compensation maintains improved control stability of the leaving water temperature.

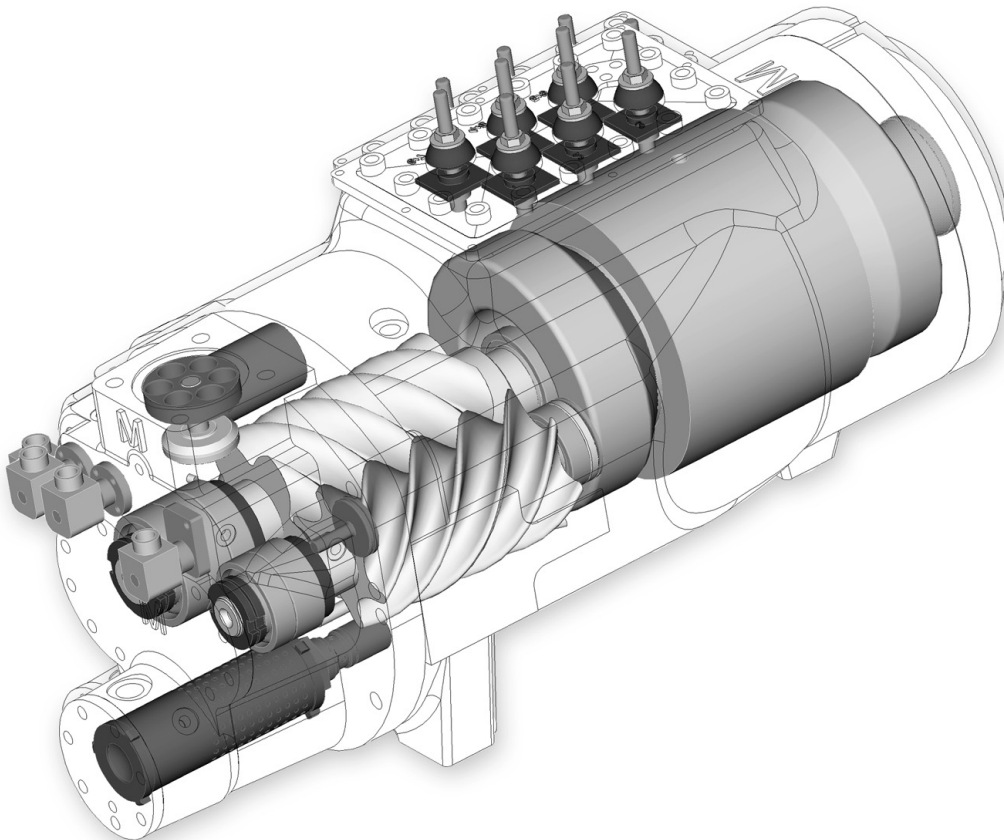



Application Considerations

Condenser Water Temperatures

With the model RTWD chiller, condenser head pressure control is necessary only if the unit starts with leaving condenser water temperatures below 45°F (7.2°C) or cannot rise to 55°F (12.8°C) within 10 minutes.

When the application requires startup temperatures below the prescribed minimums, a variety of system implementation options are available. Here are two recommended methods to control the unit operating conditions for the purpose of refrigerant differential pressure control.

1. Condenser Entering Water Temperature Control
 - Tower bypass may also be a valid control method if the chiller temperature requirements can be maintained and the loop is small.
2. Condenser Water Flow Control
 - To control a 2-way or 3-way valve, select the Condenser Regulating Valve Control option for the Trane CH530 controls. This option enables the CH530 controls to send a signal for opening and closing the valve as necessary to maintain chiller differential refrigerant pressure. The 2-way valves are available as a ship-with option.

The minimum acceptable refrigerant pressure differential between condenser and evaporator is 25 psid (172.4 kPa) at all load conditions in order to ensure adequate oil circulation. The condenser and evaporator pressure differential must be 15 psid (103.4 kPa) within 2 minutes of start up. This equates to the condenser leaving water temperature being 17°F (9.5°C) higher than evaporator leaving water temperature within 2 minutes of startup.

Trane Series R chillers start and operate successfully and reliably over a range of load conditions with controlled condenser pressure. Reducing the condenser water temperature is an effective method of lowering chiller power input required, but the ideal temperature for optimizing total system power consumption will depend on the overall system dynamics. From a system perspective, some improvements in chiller efficiency may be offset by the increased tower fan and pumping costs required to achieve the lower tower temperatures. Contact your local Trane systems solution provider for more information on optimizing system performance.

Variable Evaporator Flow and Short Evaporator Water Loops

Variable evaporator flow is an energy-saving design strategy which has quickly gained acceptance as advances in chiller and controls technology have made it possible. With its superior unloading compressor design and advanced Trane CH530 controls, the chiller has excellent capability to maintain leaving water temperature control within $\pm 0.5^\circ\text{F}$ (0.28°C), even for systems with variable evaporator flow.

Some basic rules should be followed whenever using these system design and operational savings methods with the chiller. The proper location of the chilled water temperature control sensor is in the supply (outlet) water. This location allows the building to act as a buffer, and it assures a slowly changing return water temperature. If there is insufficient water volume in the system to provide an adequate buffer, temperature control can be lost, resulting in erratic system operation and excessive compressor cycling. To ensure consistent operation and tight temperature control, the chilled water loop should be at least two minutes. If this recommendation cannot be followed, and tight leaving water temperature control is necessary, a storage tank or larger header pipe should be installed to increase the volume of water in the system.

For variable primary flow applications, the rate of chilled water flow change should not exceed 10 percent of design per minute to maintain $\pm 0.5^\circ\text{F}$ (0.28°C) leaving evaporator temperature control. For applications in which system energy savings is most important and tight temperature control is classified as $\pm 2^\circ\text{F}$ (1.1°C), up to 30 percent change in flow per minute are possible. Flow rates should be maintained between the minimum and maximum allowed for any particular chiller configuration.



Application Considerations

For applications designed to operate with changes in the water flow rate, the new evaporator water-flow compensation improves the ability of the chiller to respond to increasing or decreasing water flow. This new standard control feature works by varying the leaving evaporator temperature control gains in response to changes in evaporator water flow. By measuring the refrigerant flow in each circuit and using this value to calculate the resulting waterside temperature drop, the CH530 can estimate the water flow rate through the evaporator.

With the help of a software analysis tool such as System Analyzer™, TRACE™, or EnergyPlus™, you can determine whether the anticipated energy savings justify the use of variable primary flow in a particular application. Existing constant flow chilled water systems may be relatively easily converted to VPF and benefit greatly from the inherent efficiency advantages.

Series Chiller Arrangements

Another energy-saving strategy is to design the system around chillers arranged in series, on the evaporator, condenser, or both. It is possible to operate a pair of chillers more efficiently in a series chiller arrangement than in a parallel arrangement. It is also possible to achieve higher entering-to-leaving chiller differentials, which may, in turn, provide the opportunity for lower chilled water design temperature, lower design flow, and resulting installation and operational cost savings (including downsizing a chiller).

The Trane screw compressor also has excellent “lift” capabilities which afford an opportunity for savings on the evaporator and condenser water loops. Like series arrangements on the evaporator, series arrangements on the condenser may enable savings. This approach may allow reductions in pump and tower installation and operating costs.

Maximizing system efficiency requires that the designer balance performance considerations for all system components; the best approach may or may not involve multiple chillers, or series arrangement of the evaporators and/or condensers. This ideal balance of design integrity with installation and operating cost considerations should be researched by consulting a Trane systems solutions provider and applying the Trace™ building energy and economic analysis program.

Water-to-Water Heat Pump

The RTWD can be used as a water side heat pump by using ground or surface water as a heat source. Leaving condenser water control option provides the ability to control the heating setpoint. Local regulation concerning limitation on minimum/maximum rejected water temperature needs to be checked before using this method.

Dry Cooler

The RTWD can be used with dry coolers. Generally this application is selected to minimize the spread of airborne contaminants associated with open tower systems. In addition, other drawbacks of cooling towers are avoided: water consumption, production of vapor, need of water treatment, etc. Another benefit of dry coolers is the ability to operate in low ambient conditions. With the use of a third party heat exchanger this design can also be used to provide free cooling to the chilled water loop during cold weather.

Heat Recovery

At a time when energy costs are high and continue to rise, reducing energy usage has become increasingly important. By using a RTWD chiller with heat recovery, utilization of energy can be improved by using heat from the condenser that would otherwise be wasted.

The use of heat recovery should be considered in any building with simultaneous heating and cooling requirements or in facilities where heat can be stored and used at a later time. Buildings with high year-round internal cooling loads are excellent opportunities for heat recovery. Heat recovery can be accomplished with the RTWD by recovering heat from the water leaving the standard condenser and using it in conjunction with a third party heat exchanger.

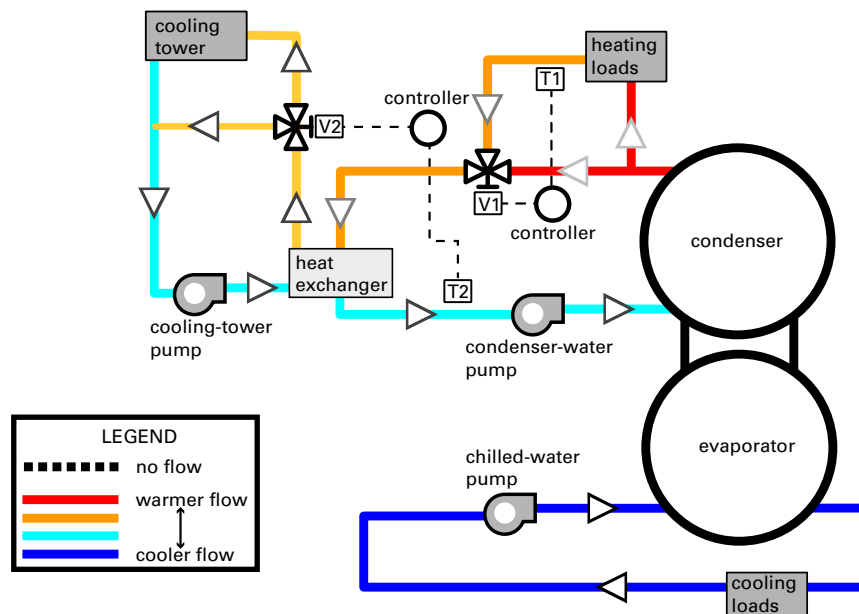

Water Treatment

The use of untreated or improperly treated water in chillers may result in scaling, erosion, corrosion, and algae or slime buildup. It is recommended that the services of a qualified water treatment specialist be engaged to determine what treatment, if any, is advisable.

Water Pumps

Where noise limitation and vibration-free operation are important, Trane strongly encourages the use of 1750-rpm (60 Hz) pumps. Specifying or using 3600-rpm (60 Hz) condenser water and chilled water pumps must be avoided, because such pumps may operate with objectionable levels of noise and vibration. In addition, a low frequency beat may occur due to the slight difference in operating rpm between 3600-rpm (60 Hz) water pumps and Series R chiller motors.

Note: The chilled water pump must not be used to stop the chiller.

Acoustic Considerations

For chiller sound ratings, installation tips, and considerations on chiller location, pipe isolation, etc., refer to the *Water-Cooled Series R Chillers Sound Ratings and Installation Guide*.

Remote Condenser

The installation of a split system offers a good economic alternative to satisfy the chilled water demand for cooling a building, particularly in the case of new construction.

The choice of a complete Trane system, including the compressor chiller and the condenser offers the designer, installer and owner the advantages of an optimized selection and undivided responsibility for the design, the quality and the operation of the complete system.

The RTUD with Trane condensers has the ability to control ambients between 14°F to 125°F (-10°C-51.7°C). The RTUD with non-Trane condensers has the ability to control ambients between 5°F to 125°F (-15°C-51.7°C).

Remote condensers should be located as close as possible to the chiller to ensure minimum pressure drops of discharge refrigerant. If non-Trane condensers are provided, a sub-cooling circuit must be provided in order to achieve cataloged performances.

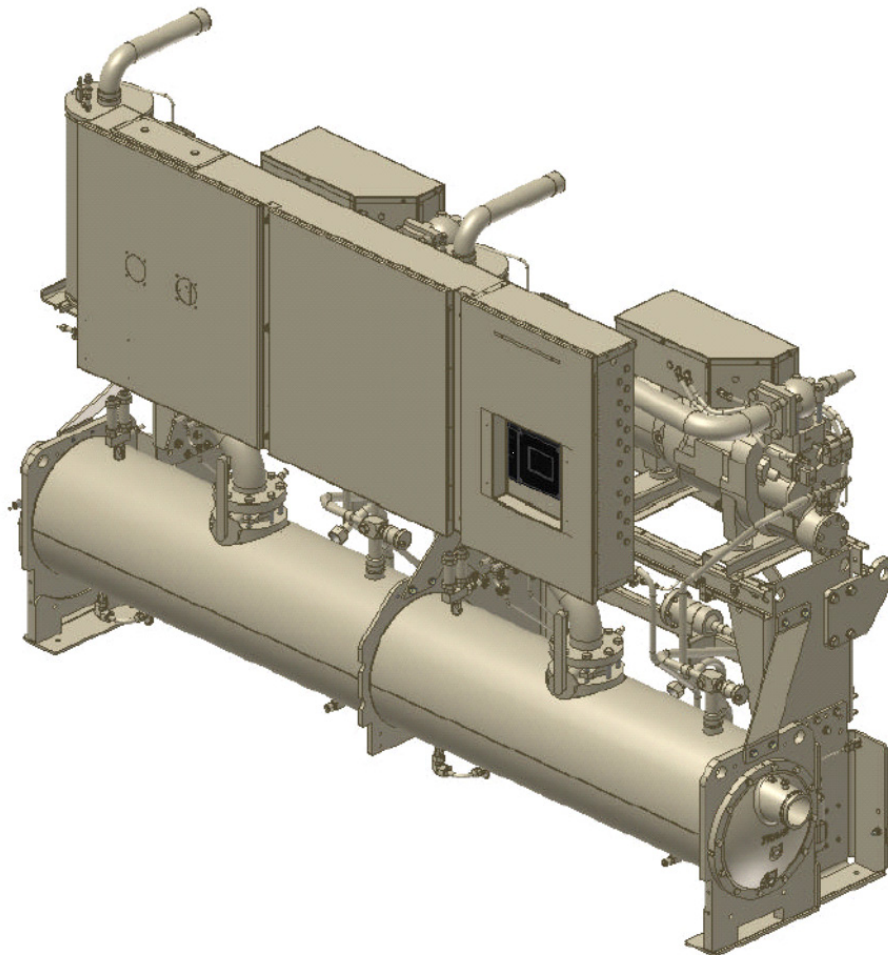



Model Number Descriptions

Digits 1-4 – Chiller Model

RTWD= Water-Cooled Series R® Chiller
RTUD= Series R® Compressor Chiller

Digits 5-7 – Unit Nominal Tonnage

060 = 60 Nominal Tons
070 = 70 Nominal Tons
080 = 80 Nominal Tons
090 = 90 Nominal Tons
100 = 100 Nominal Tons
110 = 110 Nominal Tons
120 = 120 Nominal Tons
130 = 130 Nominal Tons
140 = 140 Nominal Tons
150 = 150 Nominal Tons
160 = 160 Nominal Tons
180 = 180 Nominal Ton
200 = 200 Nominal Tons
220 = 220 Nominal Tons
250 = 250 Nominal Tons

Digit 8 – Unit Voltage

A = 200/60/3
B = 230/60/3
D = 380/60/3
F = 460/60/3
G = 575/60/3

Digit 9 – Manufacturing Plant

2 = Pueblo, USA

Digits 10, 11 – Design Sequence

** = Factory Assigned

Digit 12 – Unit Type

1 = Standard Efficiency/Performance
2 = High Efficiency/Performance
3 = Premium Efficiency/Performance

Digit 13 – Agency Listing

0 = No Agency Listing
A = UL Listed to US and Canadian Safety Standards
D = IBC Seismically Rated Unit
E = UL/Canadian and IBC
F = OSHPD Seismically Rated Unit
G = UL/Canadian and OSHPD

Digit 14 – Pressure Vessel Code

1 = ASME Pressure Vessel Code
3 = Chinese Code Pressure Vessel
S = Special

Digit 15 – Unit Application

A = Std Condenser <=95°F/35°C Entering Water Temperature
B = High Temperature Condenser >95°F/35°C Entering Water Temp
C = Water-to-Water Heat Pump
D = Remote Condenser by Trane
E = Remote Condenser by Others

Digit 16 – Pressure Relief Valve

1 = Single Relief Valve
2 = Dual Relief Valve with 3-Way Isolation Valve

Digit 17 – Water Connection Type

A = Grooved Pipe - Standard
C = Grooved Pipe - Condenser Marine

Digit 18 – Evaporator Tubes

A = Internal and External Enhanced Evap Tube

Digit 19 – Evaporator Passes

2 = 2-Pass Evaporator
3 = 3-Pass Evaporator

Digit 20 – Evaporator Water Side Pressure

A = 150 psi/10.5 bar Evaporator Water Pressure

Digit 21 – Evaporator Application

1 = Standard Cooling
2 = Low Temperature
3 = Ice Making

Digit 22 – Condenser Tubes

X = Remote Condenser
A = Enhanced Fin - Copper
B = Internally Enhanced 90/10 CuNi Fin

Digit 23 – Condenser Water Side Pressure

0 = Remote Condenser
1 = 150 psi/10.5 Bar Condenser Water Pressure

Digit 24 – Compressor Starter Type

Y = Wye-Delta Closed Transition Starter
X = Across-the-Line Starter

Digit 25 – Incoming Power Line Connection

1 = Single Point Power Connection
2 = Dual Point Power Connection

Digit 26 – Power Line Connection Type

A = Terminal Block
B = Mechanical Disconnect Switch
D = Circuit Breaker
E = High Fault Rated Panel with Circuit Breaker

Digit 27 – Under/Over Voltage Protection

0 = No Under/Over Voltage Protection
1 = Under/Over Voltage Protection

Digit 28 – Unit Operator Interface

A = DynaView™/English
B = DynaView/Spanish
C = DynaView/Spanish-Mexico
D = DynaView/French
E = DynaView/German
F = DynaView/Dutch
G = DynaView/Italian
H = DynaView/Japanese
J = DynaView/Portuguese-Portugal
K = DynaView/Portuguese-Brazil
L = DynaView/Korean
M = DynaView/Thai
N = DynaView/Simplified Chinese
P = DynaView/Traditional Chinese
R = DynaView/Russian
T = DynaView/Polish
U = DynaView/Czech
V = DynaView/Hungarian
W = DynaView/Greek
X = DynaView/Romanian
Y = DynaView/Swedish

Digit 29 – Remote Interface (Digital Comm)

0 = No Remote Digital Comm
1 = LonTalk®/Tracer™ Summit Interface
2 = Time of Day Scheduling
4 = BACnet® Interface

Digit 30 – External Water and Current Limit Setpoint

0 = No External Water and Current Limit Setpoint
A = External Water and Current Limit Setpoint 4-20 mA
B = External Water and Current Limit Setpoint 2-10 Vdc

Digit 31 – Ice Making

0 = No Ice Making
A = Ice Making with Relay
B = Ice Making without Relay

Digit 32 – Programmable Relays

0 = No Programmable Relay
A = Programmable Relay

Digit 33 – Condenser Refrigerant Pressure Output

0 = No Condenser Refrigerant Output
1 = Condenser Water Control Output
3 = Differential Pressure Output

Digit 34 – Outdoor Air Temp Sensor

0 = No Outdoor Air Temp Sensor
A = Outdoor Air Temp Sensor - CWR Low Ambient



Model Number Descriptions

Digit 35 – Condenser Leaving Hot Water Temp Control

- 0 = No Condenser Leaving Hot Water Temp Control
- 1 = Condenser Leaving Hot Water Temp Control

Digit 36 – Power Meter

- 0 = No Power Meter
- P = Power Meter

Digit 37 – Motor Current Analog Output (%RLA)

- 0 = No Motor Current Analog Output
- 1 = Motor Current Analog Output

Digit 38 – A/C Fan Control

- 0 = No Fan Controls (RTWD)
- A = Fan Control By Others
- B = Integral Fan Controls

Digit 39 – Low Ambient Fan Control

- 0 = No Low Ambient Fan Control (RTWD)
- 1 = Two Speed Fans
- 2 = Variable Speed Fan with Analog Interface
- 3 = Variable Speed Fan with PWM Interface

Digit 40 – Installation Accessories

- 0 = No Installation Accessories
- A = Elastomeric Isolators
- B = Flanged Water Connection Kit
- C = Isolators and Flanged Water Connection Kit

Digit 41 – Flow Switch

- 0 = No Flow Switch
- 1 = 150 psi NEMA 1: Flow Switch x 1
- 2 = 150 psi NEMA 1: Flow Switch x 2
- 3 = 150 psi NEMA 4: Flow Switch x 1
- 4 = 150 psi NEMA 4: Flow Switch x 2
- 7 = Factory Installed Proof of Flow (Evap/Cond)
- 8 = Factor Installed Proof of Flow (Evap)

Digit 42 – 2-Way Water Regulating Valve

- 0 = No 2-Way Water Regulating Valve
- A = 3" 150 psi/88.9 mm 10.5 bar 115V
- A = 3" 150 psi/88.9 mm 10.5 bar 220V
- A = 4" 150 psi/114.3 mm 10.5 bar 115V
- A = 4" 150 psi/114.3 mm 10.5 bar 220V

Digit 43 – Sound Reduction Package

- 0 = No Sound Reduction Package
- A = Sound Reduction - Factory Installed

Digit 44 – Insulation

- 0 = No Insulation
- 1 = Factory Insulation - All Cold Parts
- 2 = Insulation for High Humidity

Digit 45 – Factory Charge

- 0 = Full Factory Refrigerant Charge (R-134a)
- 1 = Nitrogen Charge

Digit 46 – Base Rail Forklifting

- 0 = No Base Rail Forklifting
- B = Base Rail Forklifting

Digit 47 – Label and Literature Language

- B = Spanish
- D = English
- E = French
- G = Chinese - Traditional

Digit 48 – Special

- 0 = None
- S = Special

Digits 49-55

- 0 = Not Used

Digit 56 – Shipping Package

- 0 = No Skid (Standard)
- 1 = Skid
- 2 = Shrink Wrap
- 3 = Skid + Shrink Wrap

Digit 59 – Performance Test

- 0 = No Performance Test
- C = 1-Point Test with Report
- D = 2-Point Test with Report
- E = 3-Point Test with Report
- F = 4-Point Test with Report
- G = Witness 1-Point Test with Report
- G = Witness 1-Point Test with Report Rapid Restart
- H = Witness 2-Point Test with Report
- J = Witness 3-Point Test with Report
- K = Witness 4-Point Test with Report
- K = Witness 4-Point Test with Report Rapid Restart

Digit 60 – Evaporator Fluid Type

- 0 = Water
- 1 = Calcium Chloride
- 2 = Ethylene Glycol
- 3 = Propylene Glycol
- 4 = Methanol

Digit 61 – Condenser Fluid Type

- 0 = Water
- A = Calcium Chloride
- B = Ethylene Glycol
- C = Propylene Glycol
- D = Methanol
- E = Air-Cooled Condenser



General Data

Table 1. General data – RTWD, 60 Hz, standard efficiency

Size		80	90	100	110	120	130	140
Compressor								
	Quantity	2	2	2	2	2	2	2
Evaporator								
2 Pass Arrangement								
Water Conn. Size	NPS	4	4	4	4	5	5	5
	mm	100	100	100	100	125	125	125
Water Storage	gal	11.2	11.2	12.6	14.0	15.2	16.2	17.7
	l	42.2	42.2	47.6	53.0	57.4	61.5	66.8
Minimum Flow	gpm	77	77	89	101	101	110	122
	l/s	4.9	4.9	5.6	6.3	6.3	6.9	7.6
Maximum Flow	gpm	281	281	325	368	368	400	444
	l/s	17.8	17.8	20.5	23.2	23.2	25.3	28.0
3 Pass Arrangement								
Water Conn. Size	NPS	3	3	3	3	4	4	4
	mm	80	80	80	80	100	100	100
Water Storage	gal	11.2	11.2	12.6	14.0	15.2	16.2	17.7
	l	42.2	42.2	47.6	53.0	57.4	61.5	66.8
Minimum Flow	gpm	52	52	59	67	67	73	81
	l/s	3.2	3.2	3.7	4.2	4.2	4.6	5.1
Maximum Flow	gpm	187	187	216	244	244	266	295
	l/s	11.8	11.8	13.6	15.5	15.5	16.8	18.6
Condenser								
Water Conn. Size	NPS	5	5	5	5	5	5	5
	mm	125	125	125	125	125	125	125
Water Storage (Std Waterbox)	gal	12.4	14.2	16.0	16.9	18.5	18.5	20.9
	l	46.8	53.6	60.4	63.8	70.1	70.1	79.2
Water Storage (Marine Waterbox option)	gal	29.9	31.7	33.5	34.4	36.1	36.1	38.5
	l	113.2	120.1	126.9	130.3	136.6	136.6	145.8
Minimum Flow	gpm	83	99	115	124	135	135	156
	l/s	5.2	6.2	7.3	7.8	8.5	8.5	9.8
Maximum Flow	gpm	301	361	421	451	491	491	572
	l/s	19.0	22.8	26.6	28.5	31.0	31.0	36.1
General Unit								
Refrigerant Type		R-134a	R-134a	R-134a	R-134a	R-134a	R-134a	R-134a
# Refrig Circuits		2	2	2	2	2	2	2
Refrigerant Charge	lb	114.6/114.6	114.6/114.6	112.4/114.6	112.4/112.4	132.3/132.3	130.1/130.1	127.9/132.3
	kg	52/52	52/52	51/52	51/51	60/60	59/59	58/60
Oil Charge	qt	7.2/7.2	7.2/7.2	7.2/10.5	10.5/10.5	10.5/10.5	10.5/10.5	10.5/10.5
	l	6.8/6.8	6.8/6.8	6.8/9.9	9.9/9.9	9.9/9.9	9.9/9.9	9.9/9.9

Notes:

1. Data containing information on two circuits is shown as circuit 1/circuit 2.
2. Flow limits are for water only.



General Data

Table 2. General data – RTWD, 60 Hz, high efficiency

Size		80	90	100	110	120	130
Compressor							
	Quantity	2	2	2	2	2	2
Evaporator							
2 Pass Arrangement							
Water Conn. Size	NPS	4	4	5	5	5	5
	mm	100	100	100	125	125	125
Water Storage	gal	9.8	11.9	12.8	15.3	16.4	17.3
	l	37.0	45.2	48.3	57.9	62.3	65.4
Minimum Flow	gpm	72	92	100	112	123	130
	l/s	4.5	5.8	6.3	7.0	7.7	8.2
Maximum Flow	gpm	263	336	364	409	448	476
	l/s	16.6	21.2	23.0	25.8	28.3	30.0
3 Pass Arrangement							
Water Conn. Size	NPS	3	3	4	4	4	4
	mm	80	80	80	100	100	100
Water Storage	gal	9.8	11.9	12.8	15.3	16.4	17.3
	l	37.0	45.2	48.3	57.9	62.3	65.4
Minimum Flow	gpm	48	61	67	75	82	87
	l/s	3.0	3.9	4.2	4.7	5.1	5.5
Maximum Flow	gpm	175	223	242	271	298	316
	l/s	11.1	14.1	15.3	17.2	18.8	20.0
Condenser							
Water Conn. Size	NPS	5	5	5	5	5	5
	mm	125	125	125	125	125	125
Water Storage (Std Waterbox)	gal	11.9	12.7	14.9	16.6	17.2	18.0
	l	45.1	48.1	56.3	62.7	65.2	68.3
Water Storage (Marine Waterbox option)	gal	29.5	30.3	32.9	34.2	34.8	35.7
	l	111.6	114.7	124.7	129.3	131.9	135
Minimum Flow	gpm	87	95	117	130	136	145
	l/s	5.5	6.0	7.4	8.1	8.6	9.1
Maximum Flow	gpm	317	347	427	473	498	528
	l/s	20.0	21.9	27.0	29.9	31.4	33.3
General Unit							
Refrigerant Type		R-134a	R-134a	R-134a	R-134a	R-134a	R-134a
# Refrig Circuits		2	2	2	2	2	2
Refrigerant Charge	lb	99.2/99.2	97/97	123.5/125.7	123.5/123.5	121.3/121.3	119/119
	kg	45/45	44/44	56/57	56/56	55/55	54/54
Oil Charge	qt	7.2/7.2	7.2/7.2	7.2/10.5	10.5/10.5	10.5/10.5	10.5/10.5
	l	6.8/6.8	6.8/6.8	6.8/9.9	9.9/9.9	9.9/9.9	9.9/9.9

1. Data containing information on two circuits is shown as circuit 1/circuit 2.
2. Flow limits are for water only.

Table 3. General data – RTWD, 60 Hz , high efficiency (continued)

Size		150	160	180	200	220	250
Compressor							
	Quantity	2	2	2	2	2	2
Evaporator							
2 Pass Arrangement							
Water Conn. Size	NPS	5	5	5	5	6	6
	mm	125	125	125	125	150	150
Water Storage	gal	19.2	20.3	22.3	24.2	28.6	31.8
	l	72.6	77.0	84.5	91.5	108.3	120.3
Minimum Flow	gpm	141	151	170	187	211	240
	l/s	8.9	9.5	10.7	11.8	13.3	15.1
Maximum Flow	gpm	515	554	621	683	772	879
	l/s	32.5	35.0	39.2	43.1	48.8	55.5
3 Pass Arrangement							
Water Conn. Size	NPS	4	4	4	4	4	4
	mm	100	100	100	100	100	100
Water Storage	gal	18.8	20.0	22.0	23.8	27.9	31.0
	l	71.2	75.6	83.2	90.1	105.5	117.5
Minimum Flow	gpm	94	101	113	124	141	160
	l/s	5.9	6.4	7.1	7.8	8.9	10.1
Maximum Flow	gpm	343	369	414	455	515	586
	l/s	21.7	23.3	26.2	28.7	32.5	37.0
Condenser							
Water Conn. Size	NPS	6	6	6	6	6	6
	mm	150	150	150	150	150	150
Water Storage (Std Waterbox)	gal	21.6	22.9	24.6	26.2	31.1	39.2
	l	81.7	86.8	93.0	99.2	117.8	148.3
Water Storage (Marine Waterbox option)	gal	50.0	51.4	53.0	54.6	62.2	70.3
	l	189.3	194.5	200.7	206.9	235.6	266.0
Minimum Flow	gpm	160	173	190	206	245	326
	l/s	10.1	10.9	12.0	13.0	15.4	20.5
Maximum Flow	gpm	583	634	694	754	895	1192
	l/s	36.8	40.0	43.8	47.6	56.5	75.3
General Unit							
Refrigerant Type		R-134a	R-134a	R-134a	R-134a	R-134a	R-134a
# Refriger Circuits		2	2	2	2	2	2
Refrigerant Charge	lb	134.5/143.3	141.1/141.1	138.9/138.9	136.7/136.7	178.6/185.2	180.8/180.8
	kg	61/65	64/64	63/63	62/62	81/84	82/82
Oil Charge	qt	10.5/12.4	12.4/12.4	12.4/12.4	12.4/12.4	12.4/12.4	12.4/12.4
	l	9.9/11.7	11.7/11.7	11.7/11.7	11.7/11.7	11.7/11.7	11.7/11.7

1. Data containing information on two circuits is shown as circuit 1/circuit 2.
 2. Flow limits are for water only.



General Data

Table 4. General data – RTWD, 60 Hz, premium efficiency

Size		150	160	180	200
Compressor					
	Quantity	2	2	2	2
Evaporator					
2 Pass Arrangement					
Water Conn. Size	NPS	6	6	6	6
	mm	150	150	150	150
Water Storage	(gal)	27.8	27.8	29.3	31.3
	(L)	105.1	105.1	110.9	118.3
Minimum Flow	(gpm)	175	175	187	202
	(L/s)	11.0	11.0	11.8	12.7
Maximum Flow	(gpm)	638	638	683	739
	(L/s)	40.3	40.3	43.1	46.7
3 Pass Arrangement					
Water Conn. Size	NPS	4	4	4	4
	mm	100	100	100	100
Water Storage	(gal)	27.1	27.1	28.6	30.6
	(L)	102.4	102.4	108.3	115.7
Minimum Flow	(gpm)	117	117	125	135
	(L/s)	7.3	7.3	7.8	8.5
Maximum Flow	(gpm)	425	425	455	492
	(L/s)	26.9	26.9	28.7	31.1
Condenser					
Water Conn. Size	NPS	6	6	6	6
	mm	150	150	150	150
Water Storage (Std Waterbox)	(gal)	30.0	30.0	32.9	32.9
	(L)	113.4	113.4	124.4	124.4
Water Storage (Marine Waterbox option)	(gal)	58.4	58.4	61.3	61.3
	(L)	221.1	221.1	232.1	232.1
Minimum Flow	(gpm)	206	206	231	231
	(L/s)	13.0	13.0	14.6	14.6
Maximum Flow	(gpm)	754	754	845	845
	(L/s)	47.6	47.6	53.3	53.3
General Unit					
Refrigerant Type		R-134a	R-134a	R-134a	R-134a
# Refrig Circuits		2	2	2	2
Refrigerant Charge	(lb)	174.2/183.0	183.0/183.0	180.8/180.8	178.6/178.6
	(kg)	79/83	83/83	82/82	81/81
Oil Charge	(qt)	10.5/12.4	12.4/12.4	12.4/12.4	12.4/12.4
	(L)	9.9/11.7	11.7/11.7	11.7/11.7	11.7/11.7

1. Data containing information on two circuits is shown as circuit 1/circuit 2.
2. Flow limits are for water only.

Table 5. General data – RTUD, 60 Hz

Size		80	90	100	110	120	130
Compressor							
	Quantity	2	2	2	2	2	2
Evaporator							
2 Pass Arrangement							
Water Conn. Size	NPS	4	4	4	5	5	5
	mm	100	100	100	125	125	125
Water Storage	(gal)	9.8	10.6	12.0	14.0	15.3	15.3
	(L)	37.1	40.2	45.3	53.0	58.0	58.0
Minimum Flow	(gpm)	77	79	91	99	111	111
	(L/s)	4.9	5.0	5.7	6.2	7.0	7.0
Maximum Flow	(gpm)	281	291	335	363	408	408
	(L/s)	17.7	21.2	23.0	25.8	28.3	30.0
3 Pass Arrangement							
Water Conn. Size	NPS	3	3	3	4	4	4
	mm	80	80	80	100	100	100
Water Storage	(gal)	9.5	10.3	11.6	13.7	15.1	15.1
	(L)	36.0	39.0	44.0	52.0	57.0	57.0
Minimum Flow	(gpm)	51	53	61	66	74	74
	(L/s)	3.2	3.3	3.8	4.2	4.7	4.7
Maximum Flow	(gpm)	187	194	224	242	272	272
	(L/s)	11.8	12.2	14.1	15.3	17.2	17.2
General Unit							
Refrigerant Type		R-134a	R-134a	R-134a	R-134a	R-134a	R-134a
# Refrig Circuits		2	2	2	2	2	2
Refrigerant Charge	(lb)	50/50	49/49	47/47	65/65	64/64	64/64
	(kg)	22.7/22.7	22.2/22.2	21.3/21.3	29.5/29.5	29.0/29.0	29.0/29.0
Oil Charge	(qt)	7.2/7.2	7.2/7.2	7.2/10.5	10.5/10.5	10.5/10.5	10.5/10.5
	(L)	6.8/6.8	6.8/6.8	6.8/9.9	9.9/9.9	9.9/9.9	9.9/9.9
Discharge Connection Diameter	(inch)	2.1	2.1	2.1	2.6	2.6	2.6
Liquid Connection Diameter	(inch)	1.1	1.1	1.1	1.4	1.4	1.4

1. Data containing information on two circuits is shown as circuit 1/circuit 2.
 2. Flow limits are for water only.



General Data

Table 6. General data – RTUD, 60 Hz (continued)

Size		150	160	180	200	220	250
Compressor							
	Quantity	2	2	2	2	2	2
Evaporator							
2 Pass Arrangement							
Water Conn. Size	NPS	5	5	5	5	5	5
	mm	125	125	125	125	125	125
Water Storage	(gal)	16.5	19.2	19.2	20.3	22.3	24.2
	(L)	62.4	72.6	72.6	77.0	84.5	91.5
Minimum Flow	(gpm)	122	140	140	151	169	186
	(L/s)	7.7	8.8	8.8	9.5	10.7	11.7
Maximum Flow	(gpm)	447	514	514	553	620	681
	(L/s)	28.2	32.4	32.4	34.9	39.1	43.0
3 Pass Arrangement							
Water Conn. Size	NPS	4	4	4	4	4	4
	mm	100	100	100	100	100	100
Water Storage	(gal)	16.1	18.8	18.8	20.0	22.0	23.8
	(L)	61.0	71.2	71.2	75.6	83.2	90.1
Minimum Flow	(gpm)	81	94	94	100	112	124
	(L/s)	5.1	5.9	5.9	6.3	7.1	7.8
Maximum Flow	(gpm)	298	343	343	368	413	454
	(L/s)	18.8	21.6	21.6	23.2	26.1	28.6
General Unit							
Refrigerant Type		R-134a	R-134a	R-134a	R-134a	R-134a	R-134a
# Refrig Circuits		2	2	2	2	2	2
Recommended Refrigerant Charge ^{1,3}	(lb)	62/62	66/66	66/66	66/66	63/63	61/61
	(kg)	28.1/28.1	29.9/29.9	29.9/29.9	29.9/29.9	28.6/28.6	27.7/27.7
Oil Charge ¹	(qt)	10.5/10.5	10.5/10.5	10.5/12.4	12.4/12.4	12.4/12.4	12.4/12.4
	(L)	9.9/9.9	9.9/9.9	9.9/11.7	11.7/11.7	11.7/11.7	11.7/11.7
Discharge Connection Diameter	(inch)	2.6	3.1	3.1	3.1	3.1	3.1
Liquid Connection Diameter	(inch)	1.4	1.4	1.4	1.4	1.4	1.6

1. Data containing information on two circuits is shown as circuit 1/circuit 2.

2. Flow limits are for water only.

3. Condenserless chiller is not factory charged, the refrigerant must be purchased and charged in the field.

Table 7. General data – condenser by Trane, 60 Hz

Size		80	90	100	110	120	130
Condenser							
Condenser Quantity		1	1	1	1	1	1
Fins/Inch		12	10	10	12	8	10
Coil Length	(inch)	162	216	216	216	270	270
	(mm)	4115	5486	5486	5486	6858	6858
Coil Width	(inch)	85	85	85	85	85	85
	(mm)	2159	2159	2159	2159	2159	2159
Number of Rows		3	3	4	4	4	4
Condenser Fans							
Fan Quantity		6	8	8	8	10	10
Diameter	(inch)	30	30	30	30	30	30
	(mm)	762	762	762	762	762	762
Nominal RPM	(rpm)	850	850	850	850	850	850
Air Flow	(cfm)	56,646	78,280	72,248	69,280	94,490	90,310
Tip Speed	(fpm)	6676	6676	6676	6676	6676	6676
Motor HP	(hp)	1.5	1.5	1.5	1.5	1.5	1.5
General							
Recommended Refrigerant Charge ¹	(lbs)	40/40	52/52	68/68	68/68	85/85	85/85
	(kg)	18.1/18.1	23.6/23.6	30.8/30.8	30.8/30.8	38.6/38.6	38.6/38.6
Discharge/Liquid Connection Diameters	(inch)	2.1	2.1	2.1	2.1	2.1	2.1
	(mm)	54	54	54	54	54	54

1. Data containing information on two circuits is shown as circuit 1/circuit 2.

2. Condenser is not factory charged, the refrigerant must be purchased and charged in the field.



General Data

Table 8. General data – condenser by Trane, 60 Hz (continued)

Size		150	160	180	200	220	250
Condenser							
Condenser Quantity		2	2	2	2	2	2
Fins/Inch ¹		8/12	12/12	12/8	8/8	8/10	10/10
Coil Length ¹	(inch)	162/162	162/162	162/216	216/216	216/216	216/216
		4115/4115	4115/4115	4115/5486	5486/5486	5486/5486	5486/5486
Coil Width ¹	(inch)	85/85	85/85	85/85	85/85	85/85	85/85
		2159/2159	2159/2159	2159/2159	2159/2159	2159/2159	2159/2159
Number of Rows		3/3	3/3	3/3	3/3	3/4	4/4
Condenser Fans							
Fan Quantity ¹		6/6	6/6	6/8	8/8	8/8	8/8
Diameter	(inch)	30	30	30	30	30	30
Nominal RPM	(rpm)	850	850	850	850	850	850
Air Flow ¹	(cfm)	60,954/56,646	56,646/56,646	56,646/81,272	81,272/81,272	81,272/72,248	72,248/72,248
Tip Speed	(fpm)	6676	6676	6676	6676	6676	6676
Motor HP	(hp)	1.5	1.5	1.5	1.5	1.5	1.5
General							
Recommended Refrigerant Charge ^{2,3}	(lbs)	76/76	76/76	76/101	101/101	101/134	134/134
	(kg)	34.5/34.5	34.5/34.5	34.5/45.8	45.8/45.8	45.8/60.8	60.8/60.8
Discharge/Liquid Connection Diameters	(inch)	2.125	2.125	2.125	2.125	2.125	2.125
	(mm)	54	54	54	54	54	54

1. Data containing information on two condensers is shown as cond 1/cond 2.

2. Data containing information on two circuits is shown as circuit 1/circuit 2.

3. Condenser is not factory charged, the refrigerant must be purchased and charged in the field.



Performance Data

Table 9. Performance data – RTWD, 60 Hz, standard efficiency (I-P units)

Evaporator Leaving Water Temperature (°F)	Unit Size	Condenser Entering Water Temperature (°F)											
		75				85				95			
		Tons	kW Input	EER	kW/ton	Tons	kW Input	EER	kW/ton	Tons	kW Input	EER	kW/ton
42	80	78.7	50.3	18.8	0.64	73.8	56.7	15.6	0.768	68.5	64	12.8	0.935
	90	89.7	57.3	18.8	0.639	84.6	64.4	15.7	0.762	79	72.8	13	0.921
	110	116.3	74.6	18.7	0.641	109.4	84.6	15.5	0.773	102.1	96.3	12.7	0.943
	120	127.6	80.5	19	0.631	120	91.1	15.8	0.759	112	103.4	13	0.923
	130	135.7	85.9	18.9	0.633	127.7	97.1	15.8	0.761	119.2	110.2	13	0.924
	140	148.2	94.4	18.9	0.637	139.5	106.4	15.7	0.763	130.3	120.6	13	0.925
44	80	81.8	50.7	19.4	0.62	76.7	57	16.2	0.742	71.3	64.2	13.3	0.901
	90	93.2	57.7	19.4	0.62	87.9	64.8	16.3	0.737	82.2	73	13.5	0.888
	100	106.6	66.4	19.3	0.622	100.5	74.8	16.1	0.745	93.9	84.8	13.3	0.903
	110	120.8	75.1	19.3	0.621	113.7	84.9	16.1	0.747	106.3	96.5	13.2	0.908
	120	132.6	81	19.6	0.611	124.8	91.5	16.4	0.733	116.6	103.8	13.5	0.89
	130	141	86.5	19.6	0.614	132.8	97.6	16.3	0.735	124.1	110.6	13.5	0.891
140	154.1	95	19.5	0.617	145.2	107	16.3	0.737	135.7	120.9	13.5	0.891	
46	80	85	51.1	20	0.601	79.8	57.3	16.7	0.718	74.2	64.5	13.8	0.869
	90	96.7	58.2	19.9	0.602	91.2	65.1	16.8	0.714	85.4	73.2	14	0.857
	100	110.7	66.8	19.9	0.604	104.4	75.2	16.6	0.721	97.6	85	13.8	0.871
	110	125.3	75.6	19.9	0.603	118.1	85.3	16.6	0.722	110.5	96.8	13.7	0.876
	120	137.7	81.7	20.2	0.593	129.8	92	16.9	0.709	121.4	104.2	14	0.858
	130	146.4	87.2	20.2	0.595	138.1	98.2	16.9	0.711	129.2	111	14	0.86
140	160.1	95.7	20.1	0.598	150.9	107.6	16.8	0.713	141.2	121.4	14	0.86	
48	80	88.2	51.5	20.6	0.584	82.9	57.6	17.3	0.695	77.2	64.8	14.3	0.839
	90	100.3	58.7	20.5	0.585	94.7	65.5	17.3	0.692	88.8	73.5	14.5	0.828
	100	114.8	67.3	20.5	0.587	108.3	75.6	17.2	0.698	101.5	85.4	14.3	0.841
	110	130	76.1	20.5	0.585	122.6	85.8	17.2	0.699	114.8	97.2	14.2	0.846
	120	142.9	82.3	20.8	0.576	134.8	92.6	17.5	0.687	126.2	104.6	14.5	0.829
	130	152	87.9	20.7	0.578	143.4	98.8	17.4	0.689	134.4	111.6	14.5	0.83
140	166.2	96.5	20.7	0.581	156.8	108.2	17.4	0.69	146.8	121.9	14.5	0.83	
50	80	91.5	51.9	21.2	0.567	86.1	58	17.8	0.674	80.3	65.1	14.8	0.81
	90	104	59.2	21.1	0.569	98.3	66	17.9	0.671	92.2	73.9	15	0.801
	100	119	67.8	21	0.57	112.4	76.1	17.7	0.677	105.4	85.7	14.8	0.813
	110	134.7	76.7	21.1	0.569	127.2	86.3	17.7	0.678	119.3	97.6	14.7	0.818
	120	148.3	83	21.4	0.56	140	93.2	18	0.666	131.2	105.1	15	0.801
	130	157.8	88.7	21.3	0.562	149	99.5	18	0.668	139.6	112.1	14.9	0.803
140	172.5	97.3	21.3	0.564	162.9	108.9	17.9	0.669	152.6	122.4	15	0.802	

1. Rated in accordance with AHRI Standard 550/590, based on TOPSS version 144: evaporator temperature drop of 10°F, 3 gpm/ton on the condenser, evaporator fouling factor of 0.0001°F-ft²-h/Btu and condenser fouling factor of 0.00025°F-ft²-h/Btu.
2. Performance is based on 2 pass evaporator configuration and standard condenser waterboxes.
3. Consult Trane representative for additional performance information.
4. kW input is for compressors only.
5. EER – Energy Efficiency Ratio (Btu/W-h). Power inputs include compressors and control power.
6. Interpolation between points is permissible. Extrapolation is not permitted.



Performance Data

Table 10. Performance data – RTWD, 60 Hz, high efficiency (I-P units)

Evaporator Leaving Water Temperature (°F)	Unit Size	Condenser Entering Water Temperature (°F)											
		75				85				95			
		Tons	kW Input	EER	kW/ton	Tons	kW Input	EER	kW/ton	Tons	kW Input	EER	kW/ton
40	80	80.3	49.2	19.6	0.613	75.3	55.3	16.3	0.735	69.8	62.5	13.4	0.895
	90	93.6	56.8	19.8	0.607	88	63.7	16.6	0.724	82	71.8	13.7	0.875
	100	107.8	64.9	19.9	0.603	101.2	73.2	16.6	0.723	94.3	82.9	13.7	0.879
	110	122.1	73.1	20	0.599	114.7	82.7	16.6	0.721	106.8	94	13.6	0.88
	120	130	77.9	20	0.599	122.2	88.1	16.6	0.721	113.9	100.1	13.7	0.879
	130	138.1	82.5	20.1	0.598	129.9	93.2	16.7	0.718	121.1	105.9	13.7	0.874
	150	150.5	91.2	19.8	0.606	141.6	103	16.5	0.727	132.2	116.9	13.6	0.884
	160	164.2	99.2	19.9	0.604	154.6	112	16.6	0.724	144.4	127	13.6	0.879
	180	179.1	107.1	20.1	0.598	168.8	120.6	16.8	0.714	157.9	136.5	13.9	0.865
	200	194.6	114.9	20.3	0.59	183.6	129.1	17.1	0.703	172	145.9	14.1	0.848
	220	213	129.7	19.7	0.609	201	145.9	16.5	0.726	188.4	165	13.7	0.876
250	234.2	142.8	19.7	0.61	220.9	160.6	16.5	0.727	206.9	181.6	13.7	0.878	
42	80	83.5	49.5	20.2	0.593	78.4	55.6	16.9	0.709	72.8	62.7	13.9	0.861
	90	97.3	57.3	20.4	0.588	91.6	64.1	17.2	0.699	85.5	72	14.2	0.842
	100	112.1	65.4	20.6	0.583	105.4	73.5	17.2	0.697	98.3	83.1	14.2	0.845
	110	127	73.6	20.7	0.58	119.4	83	17.3	0.695	111.4	94.2	14.2	0.846
	120	135.3	78.4	20.7	0.58	127.3	88.4	17.3	0.695	118.7	100.3	14.2	0.845
	130	143.7	83	20.8	0.578	135.3	93.6	17.3	0.692	126.3	106.1	14.3	0.84
	150	156.6	91.7	20.5	0.586	147.5	103.4	17.1	0.701	137.8	117.1	14.1	0.85
	160	170.8	99.8	20.5	0.584	161	112.4	17.2	0.698	150.5	127.2	14.2	0.845
	180	186.3	107.8	20.7	0.578	175.8	121.1	17.4	0.689	164.5	136.9	14.4	0.832
	200	202.4	115.7	21	0.572	191.1	129.7	17.7	0.679	179.2	146.4	14.7	0.817
	220	221.5	130.6	20.3	0.59	209.2	146.6	17.1	0.701	196.3	165.5	14.2	0.843
250	243.6	143.8	20.3	0.59	230	161.3	17.1	0.702	215.6	182.1	14.2	0.845	
44	80	86.9	49.9	20.9	0.574	81.6	55.9	17.5	0.685	75.9	62.9	14.5	0.829
	90	101.2	57.7	21	0.571	95.3	64.4	17.7	0.676	89.1	72.3	14.8	0.812
	100	116.6	65.9	21.2	0.565	109.8	73.9	17.8	0.673	102.5	83.4	14.8	0.813
	110	132.1	74.1	21.4	0.561	124.3	83.4	17.9	0.671	116.1	94.5	14.7	0.814
	120	140.7	78.9	21.4	0.561	132.5	88.8	17.9	0.671	123.8	100.6	14.8	0.813
	130	149.4	83.6	21.5	0.559	140.8	94	18	0.668	131.6	106.4	14.9	0.808
	150	162.8	92.3	21.2	0.567	153.5	103.8	17.7	0.677	143.6	117.4	14.7	0.818
	160	177.6	100.4	21.2	0.565	167.6	112.9	17.8	0.674	156.7	127.5	14.8	0.813
	180	193.7	108.5	21.4	0.56	182.9	121.7	18	0.665	171.4	137.3	15	0.801
	200	210.4	116.6	21.6	0.554	198.8	130.4	18.3	0.656	186.6	147	15.2	0.788
	220	230.2	131.6	21	0.572	217.6	147.4	17.7	0.677	204.3	166.1	14.8	0.813
250	253.2	144.8	21	0.572	239.2	162.2	17.7	0.678	224.5	182.7	14.8	0.814	



Performance Data

Table 10. Performance data – RTWD, 60 Hz, high efficiency (I-P units) (continued)

Evaporator Leaving Water Temperature (°F)	Unit Size	Condenser Entering Water Temperature (°F)											
		75				85				95			
		Tons	kW Input	EER	kW/ton	Tons	kW Input	EER	kW/ton	Tons	kW Input	EER	kW/ton
46	80	90.3	50.3	21.5	0.557	84.8	56.2	18.1	0.662	79	63.1	15	0.799
	90	105.2	58.3	21.7	0.554	99.1	64.9	18.3	0.654	92.7	72.6	15.3	0.783
	100	121.2	66.4	21.9	0.548	114.2	74.3	18.4	0.651	106.7	83.7	15.3	0.784
	110	137.2	74.7	22.1	0.544	129.3	83.9	18.5	0.649	120.9	94.8	15.3	0.785
	120	146.2	79.5	22.1	0.544	137.8	89.3	18.5	0.648	128.9	100.9	15.3	0.783
	130	155.3	84.2	22.1	0.542	146.5	94.5	18.6	0.645	137.1	106.7	15.4	0.778
	150	169.1	92.9	21.8	0.549	159.6	104.3	18.4	0.654	149.5	117.7	15.2	0.788
	160	184.5	101	21.9	0.548	174.3	113.4	18.4	0.651	163.1	127.8	15.3	0.783
	180	201.2	109.3	22.1	0.543	190.2	122.3	18.7	0.643	178.4	137.8	15.5	0.772
	200	218.6	117.6	22.3	0.538	206.7	131.2	18.9	0.635	194.2	147.6	15.8	0.76
	220	239	132.6	21.6	0.555	226.1	148.2	18.3	0.655	212.5	166.7	15.3	0.784
	250	263.1	145.9	21.6	0.555	248.8	163	18.3	0.655	233.7	183.3	15.3	0.784
48	80	93.7	50.7	22.2	0.541	88.2	56.5	18.7	0.641	82.2	63.4	15.6	0.771
	90	109.2	58.8	22.3	0.538	103	65.3	18.9	0.634	96.4	72.9	15.9	0.756
	100	125.9	66.9	22.6	0.532	118.7	74.8	19	0.63	111.1	84	15.9	0.756
	110	142.5	75.2	22.7	0.528	134.4	84.3	19.1	0.628	125.8	95.2	15.9	0.757
	120	151.8	80.1	22.7	0.528	143.3	89.8	19.1	0.627	134.2	101.3	15.9	0.755
	130	161.4	84.8	22.8	0.526	152.3	95	19.2	0.624	142.7	107.1	16	0.75
	150	175.6	93.6	22.5	0.533	165.9	104.9	19	0.632	155.5	118.1	15.8	0.759
	160	191.5	101.7	22.6	0.531	181.1	113.9	19.1	0.629	169.7	128.2	15.9	0.755
	180	208.9	110.1	22.8	0.527	197.6	123	19.3	0.623	185.5	138.3	16.1	0.745
	200	226.9	118.6	23	0.523	214.8	132.1	19.5	0.615	201.9	148.2	16.3	0.734
	220	248.1	133.7	22.3	0.539	234.9	149.1	18.9	0.635	221	167.4	15.8	0.758
	250	273.2	147.2	22.3	0.539	258.5	164	18.9	0.635	243	184	15.8	0.757
50	80	97.3	51.1	22.8	0.525	91.6	56.9	19.3	0.621	85.5	63.7	16.1	0.744
	90	113.3	59.4	22.9	0.524	107	65.8	19.5	0.615	100.3	73.3	16.4	0.731
	100	130.6	67.5	23.2	0.517	123.3	75.3	19.7	0.61	115.6	84.4	16.4	0.73
	110	147.8	75.9	23.4	0.513	139.6	84.9	19.7	0.608	130.9	95.6	16.4	0.731
	120	157.6	80.8	23.4	0.512	148.9	90.3	19.8	0.607	139.6	101.7	16.5	0.729
	130	167.6	85.5	23.5	0.51	158.3	95.6	19.9	0.604	148.4	107.5	16.6	0.724
	150	182.2	94.3	23.2	0.517	172.4	105.4	19.6	0.612	161.7	118.5	16.4	0.733
	160	198.7	102.4	23.3	0.515	188.1	114.5	19.7	0.609	176.4	128.6	16.5	0.729
	180	216.8	111	23.4	0.512	205.3	123.8	19.9	0.603	192.9	138.9	16.7	0.72
	200	235.5	119.7	23.6	0.508	223.1	133	20.1	0.596	209.9	149	16.9	0.71
	220	257.3	134.9	22.9	0.524	243.8	150.1	19.5	0.615	229.6	168.2	16.4	0.732
	250	283.5	148.4	22.9	0.524	268.4	165	19.5	0.615	252.6	184.8	16.4	0.732

1. Rated in accordance with AHRI Standard 550/590, based on TOPSS version 144: evaporator temperature drop of 10°F, 3 gpm/ton on the condenser, evaporator fouling factor of 0.0001°F·ft²·h/Btu and condenser fouling factor of 0.00025°F·ft²·h/Btu.
2. Performance is based on 2 pass evaporator configuration and standard condenser waterboxes.
3. Consult Trane representative for additional performance information.
4. kW input is for compressors only.
5. EER – Energy Efficiency Ratio (Btu/W·h). Power inputs include compressors and control power.
6. Interpolation between points is permissible. Extrapolation is not permitted.



Performance Data

Table 11. Performance data – RTWD, 60 Hz, premium efficiency (I-P units)

Evaporator Leaving Water Temperature (°F)	Unit Size	Condenser Entering Water Temperature (°F)											
		75				85				95			
		Tons	kW Input	EER	kW/ton	Tons	kW Input	EER	kW/ton	Tons	kW Input	EER	kW/ton
40	150	156.3	89.2	21	0.571	146.9	100.6	17.5	0.685	136.9	114.1	14.4	0.833
	160	170.6	97.5	21	0.571	160.5	109.8	17.5	0.684	149.6	124.4	14.4	0.831
	180	185.5	105.2	21.2	0.567	174.6	118.2	17.7	0.677	163.1	133.7	14.6	0.82
	200	201.2	113.5	21.3	0.564	189.6	127.2	17.9	0.671	177.5	143.6	14.8	0.809
42	150	162.9	89.8	21.8	0.551	153.3	101	18.2	0.659	143	114.3	15	0.799
	160	177.7	98	21.8	0.552	167.4	110.2	18.2	0.659	156.2	124.6	15	0.798
	180	193.1	105.9	21.9	0.548	182.1	118.7	18.4	0.652	170.2	134.1	15.2	0.787
	200	209.5	114.3	22	0.546	197.6	127.8	18.6	0.647	185.1	144.1	15.4	0.778
44	150	169.6	90.3	22.5	0.533	159.8	101.4	18.9	0.635	149.2	114.5	15.6	0.768
	160	185	98.6	22.5	0.533	174.4	110.7	18.9	0.635	162.9	124.8	15.7	0.766
	180	201	106.6	22.6	0.53	189.7	119.3	19.1	0.629	177.5	134.4	15.8	0.757
	200	218.1	115.2	22.7	0.528	205.8	128.6	19.2	0.625	193	144.6	16	0.749
46	150	176.5	91	23.3	0.515	166.4	101.9	19.6	0.612	155.6	114.8	16.3	0.738
	160	192.4	99.3	23.3	0.516	181.6	111.2	19.6	0.612	169.8	125.2	16.3	0.737
	180	209.1	107.4	23.4	0.514	197.5	120	19.8	0.607	185	134.9	16.5	0.729
	200	226.9	116.3	23.4	0.512	214.3	129.4	19.9	0.604	201.1	145.2	16.6	0.722
48	150	183.6	91.6	24	0.499	173.3	102.4	20.3	0.591	162.2	115.2	16.9	0.71
	160	200	100	24	0.5	189	111.7	20.3	0.591	176.9	125.5	16.9	0.709
	180	217.4	108.3	24.1	0.498	205.5	120.7	20.4	0.587	192.7	135.4	17.1	0.703
	200	235.9	117.3	24.1	0.498	223	130.3	20.5	0.584	209.4	145.9	17.2	0.697
50	150	190.8	92.4	24.8	0.484	180.3	103	21	0.571	168.9	115.6	17.5	0.684
	160	207.7	100.7	24.8	0.485	196.6	112.3	21	0.571	184.2	126	17.6	0.684
	180	225.8	109.2	24.8	0.484	213.7	121.4	21.1	0.568	200.6	136	17.7	0.678
	200	245.1	118.5	24.8	0.483	231.9	131.2	21.2	0.566	217.9	146.7	17.8	0.673

1. Rated in accordance with AHRI Standard 550/590, based on TOPSS version 144: evaporator temperature drop of 10°F, 3 gpm/ton on the condenser, evaporator fouling factor of 0.0001°F·ft²·h/Btu and condenser fouling factor of 0.00025°F·ft²·h/Btu.
2. Performance is based on 2 pass evaporator configuration and standard condenser waterboxes.
3. Consult Trane representative for additional performance information.
4. kW input is for compressors only.
5. EER – Energy Efficiency Ratio (Btu/W·h). Power inputs include compressors and control power.
6. Interpolation between points is permissible. Extrapolation is not permitted.

Table 12. Part load performance – RTWD, 60 Hz (I-P units)

Unit Size	% Load	Standard Efficiency				High Efficiency				Premium Efficiency			
		Tons	kW	kW/ton	IPLV kW/ton	Tons	kW	kW/ton	IPLV kW/ton	Tons	kW	kW/ton	IPLV kW/ton
80	100	76.7	57.0	0.742	0.556	81.6	55.9	0.685	0.514	n/a			
	75	57.5	35.2	0.611		61.2	34.5	0.564					
	50	38.4	19.3	0.502		40.8	18.9	0.465					
	25	19.2	11.4	0.596		20.4	11.3	0.555					
90	100	87.9	64.8	0.737	0.557	95.3	64.4	0.676	0.510	n/a			
	75	65.9	39.7	0.603		71.5	39.5	0.552					
	50	43.9	22.3	0.508		47.7	22.2	0.466					
	25	22.0	13.2	0.603		23.8	13.0	0.547					
100	100	100.5	74.8	0.745	0.554	109.7	73.9	0.673	0.496	n/a			
	75	75.3	46.4	0.616		82.3	45.7	0.556					
	50	50.2	25.6	0.509		54.9	24.8	0.453					
	25	25.1	13.4	0.533		27.4	13.1	0.479					
110	100	113.8	84.9	0.747	0.562	124.3	83.4	0.671	0.506	n/a			
	75	85.3	53.1	0.622		93.2	52.1	0.559					
	50	56.9	28.7	0.504		62.1	28.2	0.454					
	25	28.4	17.3	0.609		31.1	17.0	0.548					
120	100	124.8	91.5	0.733	0.555	132.5	88.8	0.671	0.507	n/a			
	75	93.6	57.4	0.613		99.3	55.8	0.562					
	50	62.4	31.5	0.505		66.2	30.4	0.460					
	25	31.2	17.6	0.563		33.1	17.2	0.520					
130	100	132.8	97.6	0.735	0.563	140.8	94.0	0.668	0.513	n/a			
	75	99.6	61.5	0.618		105.6	59.4	0.562					
	50	66.4	33.6	0.506		70.4	32.4	0.460					
	25	33.2	20.7	0.623		35.2	20.3	0.568					
140	100	145.2	107.0	0.737	0.556	n/a				n/a			
	75	108.9	68.2	0.627									
	50	72.6	36.1	0.497									
	25	36.3	20.7	0.570									
150	100	n/a				153.5	103.8	0.677	0.517	159.8	101.4	0.635	0.483
	75	n/a				115.1	66.4	0.577		119.8	65.1	0.543	
	50	n/a				76.7	35.9	0.467		79.9	34.4	0.430	
	25	n/a				38.4	20.3	0.528		39.9	20.3	0.509	
160	100	n/a				167.6	112.9	0.674	0.521	174.4	110.7	0.635	0.492
	75	n/a				125.7	73.0	0.581		130.8	71.5	0.547	
	50	n/a				83.8	38.8	0.463		87.2	37.9	0.434	
	25	n/a				41.9	24.2	0.578		43.6	24.7	0.566	
180	100	n/a				182.9	121.7	0.666	0.510	189.7	119.3	0.629	0.482
	75	n/a				137.2	78.1	0.570		142.3	76.5	0.538	
	50	n/a				91.4	41.7	0.456		94.8	40.5	0.427	
	25	n/a				45.7	24.7	0.540		47.4	25.2	0.530	
200	100	n/a				198.8	130.4	0.656	0.511	205.8	128.6	0.625	0.486
	75	n/a				149.1	83.2	0.558		154.4	81.9	0.531	
	50	n/a				99.4	45.7	0.460		102.9	44.9	0.437	
	25	n/a				49.7	28.2	0.567		51.5	28.2	0.547	



Performance Data

Table 12. Part load performance – RTWD, 60 Hz (I-P units) (continued)

Unit Size	% Load	Standard Efficiency				High Efficiency				Premium Efficiency			
		Tons	kW	kW/ton	IPLV kW/ton	Tons	kW	kW/ton	IPLV kW/ton	Tons	kW	kW/ton	IPLV kW/ton
220	100					217.6	147.4	0.677					
	75			n/a		163.2	94.9	0.582	0.527			n/a	
	50			n/a		108.8	52.5	0.483				n/a	
	25			n/a		54.4	28.5	0.523				n/a	
250	100					239.2	162.2	0.678					
	75			n/a		179.4	105.3	0.587	0.528			n/a	
	50			n/a		119.6	56.1	0.469				n/a	
	25			n/a		59.8	34.9	0.584				n/a	

1. Rated in accordance with AHRI Standard 550/590, based on TOPSS version 144: evaporator leaving temperature of 44°F and 2.4 gpm/ton, 2 pass evaporator, condenser entering temperature of 85°F and 3 gpm/ton with condenser relief down to 65°F at 50% and 25% loads, evaporator fouling factor of 0.0001°F·ft²·h/Btu and condenser fouling factor of 0.00025°F·ft²·h/Btu.
2. Consult Trane representative for additional performance information.
3. kW input is for compressors only. EER – Energy Efficiency Ratio (Btu/W·h). Power inputs include compressors and control power.

Table 13. Performance data RTWD – 60 Hz, standard efficiency (SI units)

Evaporator Leaving Water Temperature (°C)	Unit Size	Condenser Entering Water Temperature (°C)								
		30			32			34		
		kW Cooling	kW Input	COP	kW Cooling	kW Input	COP	kW Cooling	kW Input	COP
5	80	252.8	56.7	4.46	246.47	59.2	4.17	240.14	61.7	3.89
	90	290.07	64.5	4.49	283.39	67.3	4.21	276.71	70.2	3.94
	110	375.51	84.7	4.43	366.72	88.6	4.14	357.58	92.7	3.86
	120	411.72	91.3	4.51	401.88	95.4	4.21	392.03	99.7	3.93
	130	437.74	97.3	4.5	427.55	101.7	4.2	417.35	106.3	3.92
	140	478.53	106.6	4.49	467.63	111.4	4.2	456.03	116.3	3.92
7	80	271.44	57.3	4.73	264.75	59.7	4.43	258.07	62.3	4.14
	90	310.81	65.2	4.77	303.78	67.9	4.47	296.75	70.8	4.19
	100	355.47	75.3	4.72	347.38	78.6	4.42	339.29	82.1	4.13
	110	402.23	85.5	4.7	393.09	89.3	4.4	383.95	93.4	4.11
	120	441.96	92.2	4.79	431.76	96.3	4.48	421.57	100.5	4.19
	130	470.09	98.3	4.78	459.19	102.7	4.47	448.29	107.2	4.18
9	140	513.69	107.7	4.77	502.08	112.4	4.47	490.13	117.2	4.18
	80	290.77	58	5.01	283.74	60.4	4.7	276.71	62.9	4.4
	90	332.26	66	5.04	325.23	68.6	4.73	317.49	71.4	4.44
	100	380.43	76.1	4.99	371.99	79.4	4.68	363.2	82.8	4.39
	110	430.36	86.4	4.98	420.87	90.2	4.67	411.02	94.2	4.36
	120	473.25	93.3	5.07	462.71	97.3	4.76	452.16	101.5	4.45
	130	503.49	99.5	5.06	492.24	103.8	4.74	480.99	108.3	4.44
	140	550.61	109	5.05	538.3	113.5	4.74	525.99	118.3	4.44

1. Rated in accordance with AHRI Standard 550/590, based on TOPSS version 144: an evaporator and condenser temperature delta of 5°C, evaporator fouling factor of 0.01761°K·m³/kW and condenser fouling of 0.044025°K·m³/kW.
2. Performance is based on 2 pass evaporator configuration and standard condenser waterboxes.
3. Consult Trane representative for additional performance information.
4. kW input is for compressors only.
5. COP=Coefficient of Performance. Power inputs include compressors and control power.
6. Interpolation between points is permissible. Extrapolation is not permitted.



Performance Data

Table 14. Performance data – RTWD, 60 Hz, high efficiency (SI units)

Evaporator Leaving Water Temperature (°C)	Unit Size	Condenser Entering Water Temperature (C)								
		30			32			34		
		kW Cooling	kW Input	COP	kW Cooling	kW Input	COP	kW Cooling	kW Input	COP
5	80	268.27	55.7	4.81	261.59	58.1	4.5	254.56	60.6	4.2
	90	313.63	64.2	4.88	306.24	66.9	4.58	298.86	69.7	4.28
	100	361.09	73.7	4.89	352.3	77	4.58	343.86	80.4	4.28
	110	408.91	83.4	4.9	399.07	87.1	4.58	389.22	91.1	4.27
	120	435.63	88.8	4.9	425.44	92.8	4.58	414.89	97	4.28
	130	463.06	94	4.92	452.16	98.2	4.6	441.26	102.6	4.3
	150	504.9	103.8	4.86	493.29	108.4	4.55	481.34	113.3	4.25
	160	551.31	112.9	4.88	538.65	117.8	4.57	525.64	123	4.27
	180	601.94	121.6	4.95	588.23	126.9	4.64	574.51	132.5	4.34
	200	654.33	130.2	5.02	639.91	135.8	4.71	625.5	141.7	4.41
	220	716.56	147.1	4.87	701.09	153.4	4.57	684.92	160.1	4.28
	250	787.58	161.9	4.86	770	168.9	4.56	752.42	176.2	4.27
7	80	287.96	56.3	5.11	281.28	58.7	4.79	273.9	61.1	4.48
	90	336.83	65	5.18	329.1	67.6	4.87	321.01	70.3	4.56
	100	387.81	74.5	5.2	379.02	77.7	4.88	369.88	81	4.57
	110	439.15	84.2	5.22	428.95	87.9	4.88	418.76	91.8	4.56
	120	467.98	89.6	5.22	457.43	93.5	4.89	446.53	97.6	4.57
	130	497.51	94.8	5.24	486.26	99	4.91	474.66	103.3	4.59
	150	542.52	104.7	5.18	530.21	109.2	4.85	517.91	114	4.54
	160	592.09	113.8	5.2	578.73	118.7	4.88	565.02	123.8	4.56
	180	646.24	122.7	5.26	632.18	127.9	4.94	617.76	133.4	4.63
	200	702.5	131.6	5.34	687.38	137.1	5.01	671.91	142.9	4.7
	220	768.95	148.6	5.17	752.42	154.8	4.86	735.9	161.4	4.56
	250	845.25	163.5	5.17	827.31	170.4	4.85	808.68	177.6	4.55
9	80	309.06	57	5.42	301.67	59.3	5.09	294.29	61.7	4.77
	90	361.09	65.8	5.48	353.01	68.4	5.16	344.57	71.1	4.85
	100	415.94	75.4	5.52	406.8	78.5	5.18	397.31	81.8	4.86
	110	470.79	85.1	5.53	460.24	88.7	5.19	449.7	92.5	4.86
	120	502.08	90.5	5.54	490.83	94.4	5.2	479.58	98.5	4.87
	130	533.73	95.8	5.57	522.13	99.9	5.22	509.82	104.2	4.89
	150	581.55	105.7	5.5	568.89	110.2	5.16	555.53	114.8	4.84
	160	634.64	114.8	5.52	620.57	119.6	5.19	606.51	124.7	4.86
	180	692.65	124	5.58	677.88	129.2	5.25	662.77	134.6	4.92
	200	752.78	133.2	5.65	736.95	138.6	5.31	720.78	144.3	4.99
	220	823.1	150.3	5.48	806.22	156.4	5.15	788.64	162.9	4.84
	250	905.72	165.3	5.48	886.74	172	5.15	867.4	179.1	4.84

1. Rated in accordance with AHRI Standard 550/590, based on TOPSS version 144: an evaporator and condenser temperature delta of 5°C, evaporator fouling factor of 0.01761°K·m³/kW and condenser fouling of 0.044025°K·m³/kW.
2. Performance is based on 2 pass evaporator configuration and standard condenser waterboxes.
3. Consult Trane representative for additional performance information.
4. kW input is for compressors only.
5. COP=Coefficient of Performance. Power inputs include compressors and control power.
6. Interpolation between points is permissible. Extrapolation is not permitted.

Table 15. Performance data – RTWD, 60 Hz, premium efficiency (SI units)

Evaporator Leaving Water Temperature (°C)	Unit Size	Condenser Entering Water Temperature (°C)								
		30			32			34		
		kW Cooling	kW Input	COP	kW Cooling	kW Input	COP	kW Cooling	kW Input	COP
5	150	524.59	101.5	5.17	512.28	105.9	4.83	499.62	110.7	4.51
	160	572.76	110.8	5.17	559.04	115.6	4.83	545.33	120.7	4.52
	180	623.04	119.3	5.22	608.97	124.5	4.89	594.2	129.9	4.57
	200	676.48	128.4	5.27	661.36	133.9	4.94	645.89	139.6	4.62
7	150	565.02	102.3	5.52	552.01	106.7	5.17	538.65	111.3	4.84
	160	616.71	111.7	5.52	602.29	116.4	5.17	587.88	121.4	4.84
	180	670.85	120.5	5.57	655.73	125.5	5.22	640.26	130.9	4.89
	200	727.81	129.8	5.6	711.64	135.2	5.26	695.46	140.9	4.94
9	150	607.56	103.4	5.88	594.2	107.7	5.52	580.14	112.2	5.17
	160	662.41	112.7	5.87	647.65	117.4	5.52	632.53	122.3	5.17
	180	720.43	121.8	5.92	704.96	126.7	5.56	688.78	132	5.22
	200	781.61	131.4	5.94	764.73	136.7	5.59	747.85	142.3	5.25

1. Rated in accordance with AHRI Standard 550/590, based on TOPSS version 144: an evaporator and condenser temperature delta of 5°C, evaporator fouling factor of 0.01761°K·m³/kW and condenser fouling of 0.044025°K·m³/kW.
2. Performance is based on 2 pass evaporator configuration and standard condenser waterboxes.
3. Consult Trane representative for additional performance information.
4. kW input is for compressors only.
5. COP—Coefficient of Performance. Power inputs include compressors and control power.
6. Interpolation between points is permissible. Extrapolation is not permitted.



Performance Data

Table 16. Performance data — RTUD, Trane air-cooled condenser, 60 Hz (I-P units)

Evaporator Leaving Water Temperature (°F)	Unit Size	Condenser Entering Air Temperature (°F)														
		75			85			95			105			115		
		Tons	kW Input	EER	Tons	kW Input	EER	Tons	kW Input	EER	Tons	kW Input	EER	Tons	kW Input	EER
40	80	74.3	70.5	12.6	69.3	75.6	11	64.1	81.5	9.4	57.9	88	7.9	51.4	95.2	6.5
	90	89.8	84.7	12.7	84.1	90.5	11.2	78.1	97.2	9.6	71.3	104.7	8.2	63.9	112.9	6.8
	100	100.6	94.1	12.8	94.1	100.8	11.2	87.3	108.5	9.7	79.4	117.1	8.1	70.9	126.6	6.7
	110	112.5	105	12.8	105	112.6	11.2	97.3	121.3	9.6	88	130.9	8.1	78.2	141.7	6.6
	120	121.5	113.2	12.9	113.7	120.9	11.3	105.6	129.8	9.8	96.3	139.9	8.3	86.1	151.1	6.8
	130	129.4	118.8	13.1	121.2	127	11.5	112.7	136.5	9.9	103.2	147.2	8.4	92.7	159.1	7
	150	137.4	131.2	12.6	128.8	140.4	11	119.8	151	9.5	109.3	162.9	8.1	98.1	176	6.7
	160	148.3	139.9	12.7	139.2	149.7	11.2	129.8	161.1	9.7	118.8	173.8	8.2	106.8	187.8	6.8
	180	162.3	153	12.7	152.5	163.9	11.2	142.4	176.4	9.7	130.7	190.4	8.2	118.1	205.9	6.9
	200	177.9	166.8	12.8	167.3	178.7	11.2	156.3	192.4	9.7	143.8	207.7	8.3	130.4	224.6	7
	220	194.4	183.9	12.7	182.9	196.5	11.2	171	211.1	9.7	157.3	227.5	8.3	142.6	245.8	7
250	211.5	201.6	12.6	199.2	214.8	11.1	186.3	230.3	9.7	171.4	247.8	8.3	155.4	267.4	7	
42	80	77	71.7	12.9	71.9	76.9	11.2	66.5	82.8	9.6	60.3	89.4	8.1	53.6	96.6	6.7
	90	93.1	86.2	13	87.2	92.1	11.4	81.1	98.8	9.9	74.1	106.3	8.4	66.6	114.6	7
	100	104.3	95.9	13.1	97.7	102.6	11.4	90.6	110.3	9.9	82.6	119	8.3	73.8	128.5	6.9
	110	116.6	107.1	13.1	108.9	114.7	11.4	100.9	123.4	9.8	91.5	133.2	8.2	81.4	144	6.8
	120	126	115.3	13.1	118	123	11.5	109.7	132	10	100.1	142.1	8.4	89.7	153.4	7
	130	134.2	121	13.3	125.8	129.2	11.7	117.1	138.8	10.1	107.2	149.6	8.6	96.6	161.6	7.2
	150	142.5	133.6	12.8	133.6	142.8	11.2	124.4	153.5	9.7	113.7	165.4	8.2	102.2	178.6	6.9
	160	153.8	142.5	13	144.5	152.4	11.4	134.8	163.8	9.9	123.5	176.5	8.4	111.3	190.6	7
	180	168.3	155.8	13	158.2	166.7	11.4	147.8	179.3	9.9	135.8	193.4	8.4	122.9	208.9	7.1
	200	184.4	169.8	13	173.4	181.8	11.5	162.1	195.5	10	149.4	210.9	8.5	135.6	227.9	7.1
	220	201.5	187.5	12.9	189.7	200.1	11.4	177.4	214.7	9.9	163.4	231.2	8.5	148.3	249.5	7.1
250	219.2	205.7	12.8	206.5	218.9	11.3	193.2	234.5	9.9	177.9	252.1	8.5	161.5	271.8	7.1	
44	80	79.8	73	13.1	74.5	78.2	11.4	69.1	84.2	9.8	62.6	90.8	8.3	55.8	98	6.8
	90	96.5	87.8	13.2	90.5	93.7	11.6	84.2	100.5	10.1	77	108	8.6	69.2	116.3	7.1
	100	108.1	97.7	13.3	101.2	104.4	11.6	94	112.2	10	85.7	120.9	8.5	76.8	130.5	7.1
	110	120.8	109.2	13.3	112.9	116.8	11.6	104.7	125.7	10	94.9	135.4	8.4	84.7	146.3	6.9
	120	130.6	117.5	13.3	122.4	125.3	11.7	113.8	134.3	10.2	104	144.5	8.6	93.4	155.8	7.2
	130	139	123.2	13.5	130.4	131.5	11.9	121.5	141.1	10.3	111.4	151.9	8.8	100.5	164	7.4
	150	147.7	136	13	138.6	145.3	11.4	129	156.1	9.9	118.1	168	8.4	106.3	181.3	7
	160	159.5	145.1	13.2	149.9	155	11.6	139.9	166.5	10.1	128.3	179.3	8.6	115.8	193.5	7.2
	180	174.4	158.6	13.2	164	169.6	11.6	153.3	182.2	10.1	141	196.4	8.6	127.8	212	7.2
	200	191	172.9	13.3	179.7	184.9	11.7	168.1	198.7	10.2	155	214.1	8.7	141	231.2	7.3
	220	208.7	191.1	13.1	196.5	203.7	11.6	183.9	218.5	10.1	169.5	235	8.7	154.1	253.4	7.3
250	227	209.8	13	213.9	223.1	11.5	200.2	238.8	10.1	184.5	256.4	8.6	167.7	276.2	7.3	



Performance Data

Table 16. Performance data – RTUD, Trane air-cooled condenser, 60 Hz (I-P units) (continued)

Evaporator Leaving Water Temperature (°F)	Unit Size	Condenser Entering Air Temperature (°F)														
		75			85			95			105			115		
		Tons	kW Input	EER	Tons	kW Input	EER	Tons	kW Input	EER	Tons	kW Input	EER	Tons	kW Input	EER
46	80	82.6	74.3	13.3	77.2	79.6	11.6	71.6	85.5	10	65	92.1	8.5	58.1	99.4	7
	90	99.9	89.4	13.4	93.7	95.3	11.8	87.3	102.1	10.3	79.9	109.7	8.7	72	118.1	7.3
	100	111.9	99.5	13.5	104.9	106.3	11.8	97.4	114.2	10.2	88.9	122.9	8.7	79.8	132.6	7.2
	110	125	111.4	13.5	116.9	119	11.8	108.4	127.9	10.2	98.5	137.7	8.6	88	148.6	7.1
	120	135.3	119.7	13.6	126.8	127.5	11.9	118	136.6	10.4	107.9	146.8	8.8	97.1	158.2	7.4
	130	144	125.5	13.8	135.2	133.8	12.1	125.9	143.4	10.5	115.6	154.4	9	104.5	166.5	7.5
	150	153	138.5	13.3	143.6	147.8	11.7	133.8	158.7	10.1	122.5	170.7	8.6	110.5	184	7.2
	160	165.2	147.8	13.4	155.4	157.8	11.8	145	169.3	10.3	133.1	182.2	8.8	120.3	196.4	7.4
	180	180.5	161.5	13.4	169.9	172.5	11.8	158.8	185.3	10.3	146.3	199.4	8.8	132.8	215.1	7.4
	200	197.7	176.1	13.5	186.1	188.1	11.9	174.2	202	10.3	160.7	217.5	8.9	146.4	234.6	7.5
	220	216	194.8	13.3	203.5	207.5	11.8	190.5	222.3	10.3	175.7	238.8	8.8	159.9	257.3	7.5
250	234.9	214.1	13.2	221.4	227.4	11.7	207.3	243.1	10.2	191.1	260.8	8.8	174	280.7	7.4	
48	80	85.5	75.7	13.6	79.9	80.9	11.9	74.2	86.9	10.2	67.5	93.6	8.7	60.4	100.9	7.2
	90	103.4	91	13.6	97.1	97	12	90.4	103.8	10.4	82.9	111.5	8.9	74.8	119.9	7.5
	100	115.8	101.4	13.7	108.6	108.3	12	100.9	116.2	10.4	92.2	124.9	8.9	82.9	134.6	7.4
	110	129.3	113.6	13.7	121	121.3	12	112.2	130.2	10.3	102	140.1	8.7	91.3	151	7.3
	120	140.1	122	13.8	131.3	129.8	12.1	122.2	138.9	10.6	111.9	149.2	9	100.9	160.6	7.5
	130	149.1	127.8	14	140	136.1	12.3	130.5	145.8	10.7	119.9	156.8	9.2	108.5	169.1	7.7
	150	158.3	141	13.5	148.7	150.4	11.9	138.6	161.3	10.3	127.1	173.4	8.8	114.8	186.8	7.4
	160	171.1	150.6	13.6	160.9	160.6	12	150.3	172.2	10.5	138.1	185.1	9	125	199.3	7.5
	180	186.8	164.5	13.6	175.9	175.6	12	164.5	188.3	10.5	151.6	202.6	9	137.8	218.3	7.6
	200	204.5	179.3	13.7	192.6	191.4	12.1	180.3	205.3	10.5	166.6	220.8	9.1	151.9	238	7.7
	220	223.5	198.6	13.5	210.6	211.3	12	197.2	226.1	10.5	182	242.7	9	165.9	261.3	7.6
250	243	218.4	13.4	229.1	231.8	11.9	214.5	247.5	10.4	197.9	265.3	9	180.3	285.2	7.6	

1. Rated in accordance with AHRI Standard 550/590, based on TOPSS version 144: evaporator temperature drop of 10°F, evaporator fouling factor of 0.0001°F·ft²·h/Btu, sea level altitude.
2. Performance is based on 2 pass evaporator configuration and standard condenser waterboxes.
3. Consult Trane representative for additional performance information.
4. kW input is for compressors and control power.
5. EER – Energy Efficiency Ratio (Btu/W·h). Power inputs include compressors and control power.
6. Interpolation between points is permissible. Extrapolation is not permitted.



Performance Data

Table 17. Part load performance — RTUD, Trane air-cooled condenser, 60 Hz (I-P units)

Unit Size	% Load	Tons	EER	IPLV		Unit Size	% Load	Tons	EER	IPLV	
				EER	kw/ton					EER	kw/ton
RTUD 80	100	69.1	9.8	14.01	0.857	RTUD 150	100	129.0	9.9	13.25	0.906
	75	51.8	12.6				75	96.8	12.1		
	50	34.5	15.7				50	64.6	14.7		
	25	17.3	12.9				25	32.3	12.0		
RTUD 90	100	84.2	10.1	13.98	0.858	RTUD 160	100	139.9	10.1	13.53	0.887
	75	63.2	12.7				75	105.0	12.2		
	50	42.1	15.8				50	70.0	15.2		
	25	21.1	11.8				25	35.0	12.1		
RTUD 100	100	94.0	10.0	14.15	0.848	RTUD 180	100	153.3	10.1	13.48	0.890
	75	70.5	12.7				75	115.1	12.4		
	50	47.0	15.9				50	76.7	14.9		
	25	21.1	11.8				25	38.3	12.3		
RTUD 110	100	104.7	10.0	13.95	0.860	RTUD 200	100	168.1	10.2	13.57	0.884
	75	78.5	12.6				75	126.2	12.6		
	50	52.4	15.8				50	84.1	15.3		
	25	26.2	12.0				25	42.0	11.0		
RTUD 120	100	113.8	10.2	13.79	0.870	RTUD 220	100	183.9	10.1	13.48	0.890
	75	85.4	12.6				75	137.9	12.5		
	50	56.9	16.7				50	92.0	15.1		
	25	28.5	11.1				25	46.0	11.1		
RTUD 130	100	121.5	10.3	13.91	0.863	RTUD 250	100	200.2	10.1	13.46	0.892
	75	91.1	12.8				75	150.3	12.6		
	50	60.8	15.7				50	100.2	15.0		
	25	30.4	11.8				25	50.1	11.0		

1. Rated in accordance with AHRI Standard 550/590, based on TOPSS version 144: evaporator leaving temperature of 44°F and 2.4 gpm/ton, 2 pass evaporator, ambient air temperature of 95°F at 100% load and condenser relief down to 55°F at 33% loads, evaporator fouling factor of 0.0001 °F·ft²·h/Btu and sea level altitude.

2. Consult Trane representative for additional performance information.

3. kW input is for compressors only. EER – Energy Efficiency Ratio (Btu/W·h). Power inputs include compressors and control power.

Table 18. Performance data — RTUD, condenser by others, 60 Hz (I-P units)

Evaporator Leaving Water Temp (F)	Unit Size	Saturated Condenser Temperature (F)								
		105			125			145		
		Tons	kW Input	EER	Tons	kW Input	EER	Tons	kW Input	EER
40	80	74.3	61.8	14.4	63.9	73.9	10.4	50.5	89.7	6.8
	90	88.8	74	14.4	76.8	88.2	10.5	61.7	106.5	6.9
	100	99.8	83.4	14.4	86.2	99.4	10.4	68.7	120.3	6.9
	110	112.1	93.2	14.4	96.7	110.9	10.5	76.7	134.4	6.8
	120	120	99.4	14.5	103.6	118.2	10.5	82.9	143.1	7
	130	127.2	105.3	14.5	110.3	125.4	10.5	89.1	151.8	7
	150	137.6	114	14.5	119.7	135.5	10.6	97.3	163.8	7.1
	160	148.1	122.8	14.5	129.5	145.7	10.7	105.8	175.9	7.2
	180	162.1	132.5	14.7	142.1	157.9	10.8	117.2	191.1	7.4
	200	177.9	142.7	15	156.1	170.4	11	129.8	206.7	7.5
	220	193.9	160.4	14.5	170.5	189.8	10.8	141.7	228.7	7.4
	250	210.6	178.7	14.1	185.4	209.6	10.6	154.1	251.1	7.4
44	80	80.6	63.4	15.3	69.6	75.3	11.1	56	91.1	7.4
	90	96.2	76	15.2	83.6	90.1	11.1	68	108.4	7.5
	100	108.1	85.7	15.1	93.8	101.5	11.1	75.8	122.5	7.4
	110	121.5	95.9	15.2	105.2	113.4	11.1	84.7	136.8	7.4
	120	130	102.1	15.3	112.8	120.8	11.2	91.5	145.7	7.5
	130	137.8	108	15.3	120	128	11.3	98.2	154.4	7.6
	150	149.1	117.1	15.3	130.3	138.3	11.3	107.2	166.6	7.7
	160	160.6	126.2	15.3	141	148.8	11.4	116.6	178.9	7.8
	180	175.5	136	15.5	154.4	161.1	11.5	128.8	194.2	8
	200	192.4	146.4	15.8	169.5	173.9	11.7	142.4	209.9	8.1
	220	209.8	165.1	15.2	185.1	194.1	11.4	155.3	232.7	8
	250	227.7	184.4	14.8	201.2	214.7	11.2	168.7	256	7.9
48	80	87.2	65	16.1	75.7	76.8	11.8	61.6	92.5	8
	90	103.9	78.1	16	90.7	92	11.8	74.6	110.4	8.1
	100	116.8	88.1	15.9	101.8	103.8	11.8	83.3	124.7	8
	110	131.3	98.7	16	114.2	115.9	11.8	93	139.3	8
	120	140.5	105	16.1	122.5	123.4	11.9	100.5	148.2	8.1
	130	148.8	110.9	16.1	130.2	130.6	12	107.8	157	8.2
	150	161.2	120.3	16.1	141.5	141.3	12	117.6	169.4	8.3
	160	173.6	129.7	16.1	153	152.1	12.1	127.8	181.9	8.4
	180	189.6	139.8	16.3	167.4	164.5	12.2	140.9	197.4	8.6
	200	207.7	150.4	16.6	183.6	177.4	12.4	155.6	213.3	8.8
	220	226.4	170.1	16	200.4	198.6	12.1	169.5	236.9	8.6
	250	245.6	190.4	15.5	217.7	220.2	11.9	184	261.1	8.5

1. Rated in accordance with AHRI Standard 550/590, based on TOPSS version 144: evaporator temperature drop of 10°F, 20°F sub-cooling, evaporator fouling factor of 0.0001 °F·ft²·h/Btu, sea level altitude.
2. Based on 2 pass evaporator configuration.
3. Consult Trane representative for additional performance information.
4. kW input is for compressors and control power.
5. EER – Energy Efficiency Ratio (Btu/W·h). Power inputs include compressors and control power.
6. Interpolation between points is permissible. Extrapolation is not permitted.



Performance Data

Table 19. Performance data — RTUD, condenser by others, 60 Hz (SI units)

Evaporator Leaving Water Temperature (°C)	Unit Size	Saturated Condenser Temperature (°C)								
		40			50			60		
		kW Cooling	kW Input	COP	kW Cooling	kW Input	COP	kW Cooling	kW Input	COP
5	80	265.46	61.7	4.3	232.41	72.2	3.22	191.97	85.7	2.24
	90	316.79	73.9	4.29	278.82	86.2	3.23	233.11	102	2.28
	100	356.17	83.3	4.28	313.28	97.2	3.22	260.18	115.1	2.26
	110	400.12	93.1	4.3	351.25	108.5	3.24	290.77	128.6	2.26
	120	428.25	99.2	4.32	376.56	115.6	3.26	313.63	136.9	2.29
	130	453.92	105.1	4.32	400.47	122.6	3.26	336.13	145.2	2.31
	150	491.19	113.8	4.31	434.58	132.5	3.28	366.37	156.8	2.34
	160	528.45	122.6	4.31	469.39	142.6	3.29	397.66	168.4	2.36
	180	578.38	132.3	4.37	514.74	154.4	3.33	439.15	182.8	2.4
	200	634.29	142.4	4.45	565.02	166.5	3.39	484.86	197.6	2.45
	220	691.6	160.3	4.31	617.06	185.8	3.32	529.16	219	2.42
	250	750.67	178.7	4.2	670.85	205.5	3.26	575.22	240.9	2.39
7	80	285.5	63.1	4.52	250.69	73.5	3.41	209.2	87	2.4
	90	340.35	75.7	4.5	300.62	87.9	3.42	253.15	103.7	2.44
	100	382.54	85.4	4.48	337.54	99.2	3.4	283.04	117.1	2.42
	110	430.01	95.5	4.5	378.67	110.7	3.42	316.44	130.8	2.42
	120	460.24	101.7	4.52	406.1	117.9	3.44	341.4	139.2	2.45
	130	487.32	107.6	4.53	431.41	124.9	3.45	365.31	147.5	2.47
	150	527.75	116.6	4.52	468.68	135.1	3.47	398.36	159.3	2.5
	160	568.19	125.7	4.52	506.3	145.4	3.48	432.12	171.1	2.53
	180	620.93	135.5	4.58	554.12	157.3	3.52	476.42	185.7	2.57
	200	680.35	145.8	4.67	608.27	169.7	3.58	525.29	200.6	2.62
	220	741.88	164.6	4.51	663.82	189.7	3.5	573.11	222.8	2.57
	250	804.81	183.9	4.38	721.48	210.2	3.43	622.33	245.4	2.54
9	80	305.89	64.6	4.74	270.03	74.9	3.6	227.49	88.3	2.57
	90	364.61	77.5	4.7	323.47	89.7	3.6	274.6	105.4	2.6
	100	409.97	87.6	4.68	363.2	101.2	3.59	306.95	119	2.58
	110	460.95	98.1	4.7	407.5	113.1	3.6	343.51	133	2.58
	120	493.29	104.3	4.73	437.04	120.3	3.63	370.23	141.5	2.62
	130	522.13	110.2	4.74	463.76	127.3	3.64	395.9	149.9	2.64
	150	566.08	119.6	4.73	504.19	137.8	3.66	431.76	161.8	2.67
	160	609.32	128.9	4.72	544.63	148.3	3.67	468.33	173.9	2.69
	180	665.23	138.9	4.79	595.61	160.4	3.71	515.09	188.6	2.73
	200	728.87	149.4	4.88	652.92	172.9	3.77	567.48	203.6	2.79
	220	794.26	169.1	4.69	712.69	193.8	3.67	618.46	226.6	2.73
	250	861.42	189.4	4.55	773.87	215.2	3.6	671.56	250	2.69

1. Based on TOPSS version 144: evaporator temperature drop of 5°C, 10°C sub-cooling, evaporator fouling factor of 0.01761°K·m³/kW and sea level altitude.
2. Performance is based on 2 pass evaporator configuration.
3. Consult Trane representative for additional performance information.
4. kW input is for compressors and control power.
5. COP—Coefficient of Performance. Power inputs include compressors and control power.
6. Interpolation between points is permissible. Extrapolation is not permitted.



Controls

LCD Touch-Screen Display with Multi-Language Support

The standard DynaView display provided with the Trane CH530 control panel features an LCD touch-screen, allowing access to all operational inputs and outputs. This display supports many languages including: English, Chinese, Dutch, French, German, Italian, Japanese, Korean, Portuguese, Spanish, and Thai.

Display Features Include:

- LCD touch-screen with LED backlighting, for scrolling access to input and output operating information
- Single-screen, folder/tab-style display of all available information on individual components (evaporator, condenser, compressor, etc.)
- Manual override indication
- Password entry/lockout system to enable or disable display
- Automatic and immediate stop capabilities for standard or immediate manual shutdown
- Fast, easy access to available chiller data in tabbed format, including:
 - Modes of operation, including normal cooling, ice making and hot water control
 - Water temperatures and setpoints, outdoor air temperature
 - Loading and limiting status and setpoints
 - Average line current
 - Start/stop differential timers
 - Auto/Manual mode for EXV, slide valve, and head pressure control
 - Pump status and override
 - Chilled water reset settings
 - Optional external setpoints, including:
 - Chilled water, current-limit, condenser leaving hot water temperature setpoint
 - Ice building
- Reports, listed on a single tabbed screen for easy access, including:
 - ASHRAE, containing all guideline 3 report information
 - Evaporator, condenser, compressor
- Evaporator, condenser, and compressor reports containing all operational information on individual components, including:
 - Water temperatures
 - Refrigerant pressures, temperatures, and approach
 - Oil pressure, head pressure control command
 - Flow switch status, EXV position
 - Compressor starts and run-time
 - Line phase percent RLA, amps, and volts
- Alarm and diagnostic information, including:
 - Flashing alarms with touch-screen button of alarm condition
 - Scrollable list of last ten active diagnostics
 - Specific information on applicable diagnostic from list of over one-hundred
 - Automatic or manual resetting diagnostic types

LonTalk/Tracer Summit Interface

LonTalk® (LCI-C) or Tracer® Summit communications capabilities are available, with communication link via single twisted-pair wiring to factory-installed, tested communication board.

Required features:

- LonTalk/Tracer Summit Interface

Additional options that may be used:

- Ice making, chilled water temperature reset - outdoor air

External devices required:

- Trane Tracer system or LonTalk compatible system level interface.

Easy Operation and Maintenance

- Remote monitoring and control
- Displays both current operation conditions and scheduled automated control actions
- Concise reports assist in planning for preventative maintenance and verifying performance
- Alarm notification and diagnostic messages aid in quick and accurate troubleshooting

When integrated with a Tracer Summit building management system the total building operation can be optimized. With this system option, the full breadth of Trane's HVAC and controls experience are applied to offer solutions to many facility issues.

LonTalk Chiller Controls

LonTalk is a communications protocol developed by the Echelon™ Corporation. The LonMark™ association develops control profiles using the LonTalk communication protocol. LonTalk is a unit level communications protocol.

LonTalk Communications Interface for Chillers (LCI-C) provides a generic automation system with the LonMark chiller profile inputs/outputs. In addition to the standard points, Trane provides other commonly used network output variables for greater interoperability with any automation system. The complete reference list of Trane LonTalk points is available on the LonMark web site.

Trane controls or another vendor's system can use the predefined list of points with ease to give the operator a complete picture of how the system is running.

Tracer Summit

Trane's depth of experience in chillers and controls makes us a well-qualified choice for automation of chiller plants using water-cooled Series R® chillers. The chiller plant control capabilities of the Trane Tracer Summit™ building automation system are unequalled in the industry. Our chiller plant automation software is fully pre-engineered and tested.

Energy Efficiency

- Sequences starting of chillers to optimize the overall chiller plant energy efficiency
- Individual chillers operate as base, peak, or swing based on capacity and efficiency
- Automatically rotates individual chiller operation to equalize runtime and wear between chillers.
- Evaluates and selects the lowest energy consumption alternative from an overall system perspective.

Regulatory Compliance Documentation

- Gathers information and generates the reports mandated in ASHRAE Guideline 3.

Tracer SC

The Tracer® SC system controller acts as the central coordinator for all individual equipment devices on a Tracer building automation system. The Tracer SC scans all unit controllers to update information and coordinate building control, including building subsystems such as VAV and chiller water systems. With this system option, the full breadth of Trane's HVAC and controls experience are applied to offer solutions to many facility issues. The LAN allows building operators to manage these varied components as one system from any personal computer with web access. The benefits of this system are:

- Improved usability with automatic data collection, enhanced data logging, easier to create graphics, simpler navigation, pre-programmed scheduling, reporting, and alarm logs.
- Flexible technology allows for system sizes from 30-120 unit controllers with any combination of LonTalk® or BACnet unit controllers.
- LEED certification through site commissioning report, energy data collection measurement, optimizing energy performance, and maintaining indoor air quality.
- Energy savings programs include: fan pressure optimization, ventilation reset, and chiller plant control (adds and subtracts chillers to meet cooling loads).

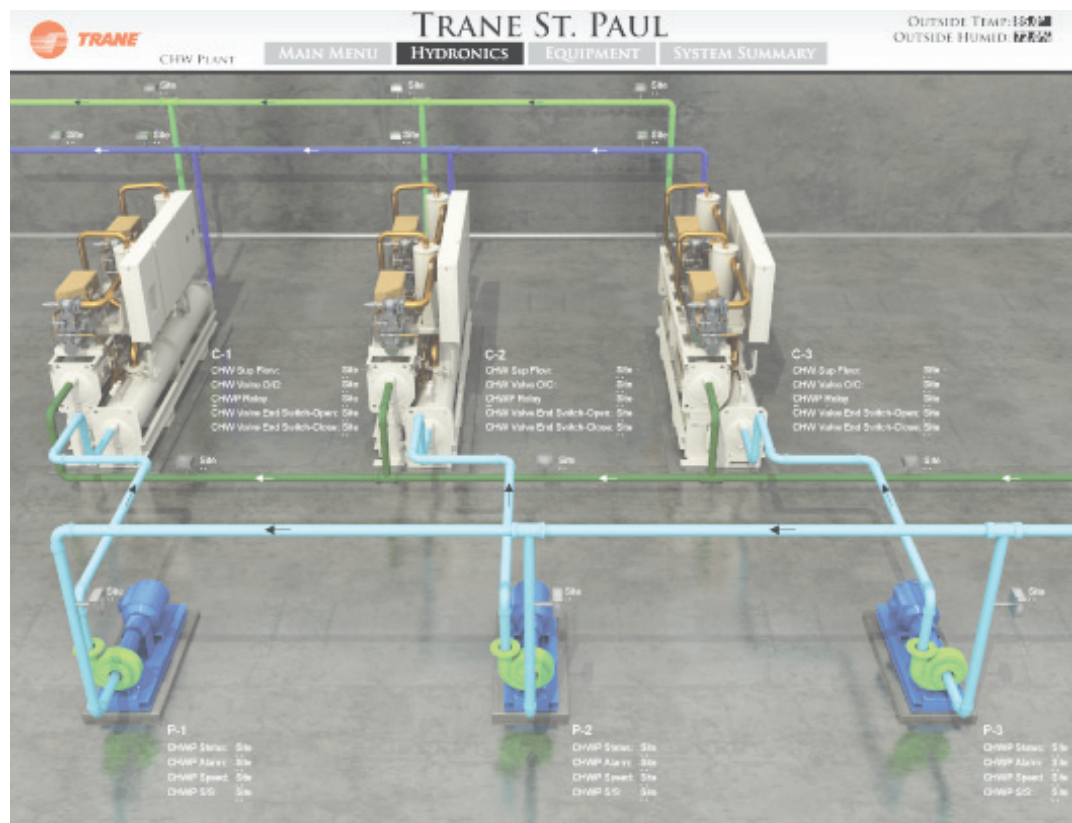

BACnet Communication Interface

BACnet® communications capabilities are available, with communication link via single twisted-pair wiring.

Required features:

- BACnet Interface

Additional options that may be used:

- Ice making, chilled water temperature reset - outdoor air

External devices required:

- BACnet MS/TP network.

BACnet Chiller Controls

BACnet is an open standard communications protocol used by building automation systems. BACnet MS/TP uses RS-485 hardware. This device is a non-programmable communication module that connects directly to the CH530 chiller control.

Time of Day Scheduling

Time of day scheduling allows the customer to perform simple chiller scheduling without the need for a building automation system.

This feature allows the user to set 10 events in a 7 day time period. For each event the user can specify an activation time and the days of the week the event is active. Any setpoints available can be specified for each event, such as the leaving chilled water temperature (standard) and the current-limit setpoint (optional if ordered).

Required features:

- Time of day scheduling

Additional options that if ordered may be incorporated into the scheduling:

- External chilled water setpoint
- External current-limit setpoint
- Condenser leaving hot water temperature setpoint
- Ice making initiation

Hardwire Points

Remote devices wired from the control panel are another reliable method of providing auxiliary control to a building automation system. Inputs and outputs can be communicated via a typical 4–20 mA electrical signal, an equivalent 2–10 Vdc signal, or by utilizing contact closures.

Selectable options:

- External chilled water setpoint/External current-limit setpoint
- Ice making control
- Condenser leaving hot water temperature control
- Chilled water temperature reset
- Condenser pressure output
- Motor current analog output
- Programmable relays available outputs are: alarm-latching, alarm-auto reset, general alarm, warning, chiller limit mode, compressor running, head pressure relief request, and Tracer control



Electrical Data

Electrical Data Tables

Table 20. Electrical data – RTWD, 60 Hz, standard efficiency, standard condensing temperature

Unit Size	Rated Voltage	Unit Wiring				Motor Data		
		Single Point Power - 1 Power Connection		Dual Point Power - 2 Power Connections		RLA	LRA YD	LRA XL
		MCA	MOP	MCA	MOP			
80	200/60/3	216	300	122/118	200/200	94/94	276/276	912/912
	230/60/3	188	250	106/103	175/175	82/82	238/238	786/786
	380/60/3	115	150	65/63	110/110	50/50	138/138	456/456
	460/60/3	94	125	53/51	90/90	41/41	114/114	376/376
	575/60/3	76	100	43/41	70/70	33/33	93/93	308/308
90	200/60/3	249	350	140/136	225/225	109/109	304/304	1003/1003
	230/60/3	217	300	122/119	200/200	95/95	262/262	866/866
	380/60/3	130	175	73/71	125/125	57/57	161/161	530/530
	460/60/3	110	150	62/60	100/100	48/48	131/131	433/433
	575/60/3	87	110	49/48	80/80	38/38	105/105	346/346
100	200/60/3	291	400	140/178	225/300	109/142	304/355	1003/1137
	230/60/3	252	350	122/154	200/250	95/123	262/294	866/942
	380/60/3	153	225	73/94	125/150	57/75	161/177	530/566
	460/60/3	127	175	62/78	100/125	48/62	131/147	433/471
	575/60/3	102	150	49/63	80/110	38/50	105/118	346/377
110	200/60/3	324	450	182/178	300/300	142/142	355/355	1137/1137
	230/60/3	280	400	157/154	250/250	123/123	294/294	942/942
	380/60/3	171	225	96/94	150/150	75/75	177/177	566/566
	460/60/3	141	200	80/78	125/125	62/62	147/147	471/471
	575/60/3	114	150	64/63	110/110	50/50	118/118	377/377
120	200/60/3	356	500	182/210	300/350	142/168	355/419	1137/1368
	230/60/3	309	450	157/183	250/300	123/146	294/367	942/1200
	380/60/3	187	250	96/110	150/175	75/88	177/229	566/747
	460/60/3	155	225	79/91	125/150	62/73	147/184	471/600
	575/60/3	125	175	64/74	110/125	50/59	118/148	377/483
130	200/60/3	382	500	214/210	350/350	168/168	419/419	1368/1368
	230/60/3	332	450	186/183	300/300	146/146	367/367	1200/1200
	380/60/3	200	250	112/110	200/175	88/88	229/229	747/747
	460/60/3	166	225	93/91	150/150	73/73	184/184	600/600
	575/60/3	134	175	75/74	125/125	59/59	148/148	483/483
140	200/60/3	425	600	214/253	350/450	168/202	419/487	1368/1498
	230/60/3	368	500	186/219	300/350	146/175	367/427	1200/1314
	380/60/3	223	300	112/133	200/225	88/106	229/260	747/801
	460/60/3	185	250	93/110	150/175	73/88	184/212	600/652
	575/60/3	148	200	75/88	125/150	59/70	148/172	483/528

Notes:

1. Voltage Utilization Range: +/- 10% of rated voltage
Rated voltage (use range): 208/60/3 (187.2-228.8), 230/60/3(208-254), 380/60/3 (342-418), 460/60/3 (414-506), 575/60/3 (516-633)
2. MCA—minimum circuit ampacity
3. MOP—maximum overcurrent protection
4. RLA—rated load amps are rated in accordance with UL Standard 1995.
5. LRA—locked rotor amps are based on full winding starts.
6. LRA YD—Locked Rotor Amps in Wye configuration. LRA XL—Locked Rotor Amps in the Delta configuration.
7. Local codes may take precedence.
8. Data containing information on two circuits shown as follows: circuit 1/circuit 2.
9. Standard condensing temperature option refers to entering condenser water temperatures 95°F (35°C) and below.



Electrical Data

Table 21. Electrical data— RTWD, 60 Hz, high efficiency, standard condensing temperature

Unit Size	Rated Voltage	Unit Wiring				Motor Data		
		Single Point Power - 1 Power Connection		Dual Point Power - 2 Power Connections		RLA	LRA YD	LRA XL
		MCA	MOP	MCA	MOP			
80	200/60/3	211	300	119/115	200/200	92/92	276/276	912/912
	230/60/3	184	250	104/100	175/175	80/80	238/238	786/786
	380/60/3	112	150	63/61	110/110	49/49	138/138	456/456
	460/60/3	92	125	52/50	90/90	40/40	114/114	376/376
	575/60/3	73	100	32/32	93/93	32/32	93/93	308/308
90	200/60/3	245	350	138/134	225/225	107/107	304/304	1003/1003
	230/60/3	213	300	120/116	200/200	93/93	262/262	866/866
	380/60/3	128	175	72/70	125/125	56/56	161/161	530/530
	460/60/3	108	150	61/59	100/100	47/47	131/131	433/433
	575/60/3	85	110	48/46	80/80	37/37	105/105	346/346
100	200/60/3	284	400	138/173	225/300	107/138	304/355	1003/1137
	230/60/3	247	350	120/150	200/250	93/120	262/294	866/942
	380/60/3	149	200	72/91	125/150	56/73	161/177	530/566
	460/60/3	124	175	61/75	100/125	47/60	131/147	433/471
	575/60/3	98	125	48/60	80/100	37/48	105/118	346/377
110	200/60/3	315	450	177/173	300/300	138/138	355/355	1137/1137
	230/60/3	274	350	154/150	250/250	120/120	294/294	942/942
	380/60/3	166	225	93/91	150/150	73/73	177/177	566/566
	460/60/3	137	175	77/75	125/125	60/60	147/147	471/471
	575/60/3	109	150	61/60	100/100	48/48	118/118	377/377
120	200/60/3	347	500	177/205	300/350	138/164	355/419	1137/1368
	230/60/3	302	400	154/179	250/300	120/143	294/367	942/1200
	380/60/3	184	250	93/109	150/175	73/87	177/229	566/747
	460/60/3	152	200	77/90	125/150	60/72	147/184	471/600
	575/60/3	121	175	61/71	100/125	48/57	118/148	377/483
130	200/60/3	373	500	209/205	350/350	164/164	419/419	1368/1368
	230/60/3	325	450	182/179	300/300	143/143	367/367	1200/1200
	380/60/3	198	250	111/109	175/175	87/87	229/229	747/747
	460/60/3	164	225	92/90	150/150	72/72	184/184	600/600
	575/60/3	130	175	73/71	125/125	57/57	148/148	483/483
150	200/60/3	414	600	210/245	350/400	164/196	419/487	1368/1498
	230/60/3	361	500	183/214	300/350	143/171	367/427	1200/1314
	380/60/3	218	300	111/129	175/225	87/103	229/260	747/801
	460/60/3	182	250	92/108	150/175	72/86	184/212	600/652
	575/60/3	145	200	73/87	125/150	57/69	148/172	483/528
160	200/60/3	446	600	250/245	400/400	196/196	487/487	1498/1498
	230/60/3	389	500	218/214	350/350	171/171	427/427	1314/1314
	380/60/3	234	300	131/129	225/225	103/103	260/260	801/801
	460/60/3	196	250	110/108	175/175	86/86	212/212	652/652
	575/60/3	157	225	88/87	150/150	69/69	172/172	528/528

Table 21. Electrical data— RTWD, 60 Hz, high efficiency, standard condensing temperature (continued)

Unit Size	Rated Voltage	Unit Wiring				Motor Data		
		Single Point Power - 1 Power Connection		Dual Point Power - 2 Power Connections		RLA	LRA YD	LRA XL
		MCA	MOP	MCA	MOP			
180	200/60/3	484	700	250/284	400/500	196/227	487/600	1498/1845
	230/60/3	421	600	218/247	350/400	171/197	427/506	1314/1556
	380/60/3	256	350	131/150	225/250	103/120	260/316	801/973
	460/60/3	213	300	110/125	175/225	86/100	212/252	652/774
	575/60/3	171	250	88/100	150/175	69/80	172/205	528/631
200	200/60/3	515	700	288/284	500/500	227/227	600/600	1845/1845
	230/60/3	447	600	250/247	400/400	197/197	506/506	1556/1556
	380/60/3	273	350	153/150	250/250	120/120	316/316	973/973
	460/60/3	227	300	127/125	225/225	100/100	252/252	774/774
	575/60/3	182	250	102/100	175/175	80/80	205/205	631/631
220	200/60/3	583	800	288/352	500/600	227/281	600/701	1845/2156
	230/60/3	509	700	250/308	400/500	197/246	506/571	1556/1756
	380/60/3	309	450	153/187	250/300	120/149	316/345	973/1060
	460/60/3	256	350	127/154	225/250	100/123	252/285	774/878
	575/60/3	204	300	102/123	175/200	80/98	205/229	631/705
250	200/60/3	637	800	356/352	600/600	281/281	701/701	2156/2156
	230/60/3	558	800	312/308	500/500	246/246	571/571	1756/1756
	380/60/3	338	450	189/187	300/300	149/149	345/345	1060/1060
	460/60/3	279	400	156/154	250/250	123/123	285/285	878/878
	575/60/3	222	300	124/123	200/200	98/98	229/229	705/705

Notes:

1. Voltage Utilization Range: +/- 10% of rated voltage
Rated voltage (use range): 208/60/3 (187.2-228.8), 230/60/3(208-254), 380/60/3 (342-418), 460/60/3 (414-506), 575/60/3 (516-633)
2. MCA—minimum circuit ampacity
3. MOP—maximum overcurrent protection
4. RLA—rated load amps are rated in accordance with UL Standard 1995.
5. LRA—locked rotor amps are based on full winding starts.
6. LRA YD—Locked Rotor Amps in Wye configuration. LRA XL—Locked Rotor Amps in the Delta configuration.
7. Local codes may take precedence.
8. Data containing information on two circuits shown as follows: circuit 1/circuit 2.
9. Standard condensing temperature option refers to entering condenser water temperatures 95°F/35°C) and below.



Electrical Data

Table 22. Electrical data – RTWD, 60 Hz, premium efficiency, standard condensing temperature

Unit Size	Rated Voltage	Unit Wiring				Motor Data		
		Single Point Power - 1 Power Connection		Dual Point Power - 2 Power Connections		RLA	LRA YD	LRA XL
		MCA	MOP	MCA	MOP			
150	200/60/3	410	600	208/243	350/400	163/194	419/487	1368/1498
	230/60/3	360	500	183/213	300/350	143/170	367/427	1200/1314
	380/60/3	277	300	110/129	175/225	86/103	229/260	747/801
	460/60/3	180	250	91/107	150/175	71/85	184/212	600/652
	575/60/3	145	200	74/85	125/150	58/68	148/172	483/528
160	200/60/3	441	600	247/243	400/400	194/194	487/487	1498/1498
	230/60/3	387	500	217/213	350/350	170/170	427/427	1314/1314
	380/60/3	234	300	131/129	225/225	103/103	260/260	801/801
	460/60/3	194	250	109/107	175/175	85/85	212/212	652/652
	575/60/3	155	200	87/85	150/150	68/68	172/172	528/528
180	200/60/3	481	700	247/283	400/500	194/226	487/600	1498/1845
	230/60/3	420	600	217/247	350/400	170/197	427/506	1314/1556
	380/60/3	256	350	131/150	225/250	103/120	260/316	801/973
	460/60/3	212	300	109/125	175/225	85/100	212/252	652/774
	575/60/3	171	250	87/102	150/175	68/81	172/205	528/631
200	200/60/3	513	700	287/283	500/500	226/226	600/600	1845/1845
	230/60/3	447	600	250/247	400/400	197/197	506/506	1556/1556
	380/60/3	275	350	153/150	250/250	120/120	316/316	973/973
	460/60/3	277	300	127/125	225/225	100/100	252/252	774/774
	575/60/3	184	250	103/102	175/175	81/81	205/205	631/631

Notes:

1. Voltage Utilization Range: +/- 10% of rated voltage
Rated voltage (use range): 208/60/3 (187.2-228.8), 230/60/3(208-254), 380/60/3 (342-418), 460/60/3 (414-506), 575/60/3 (516-633)
2. MCA—minimum circuit ampacity
3. MOP—maximum overcurrent protection
4. RLA—rated load amps are rated in accordance with UL Standard 1995.
5. LRA—locked rotor amps are based on full winding starts.
6. LRA YD—Locked Rotor Amps in Wye configuration. LRA XL—Locked Rotor Amps in the Delta configuration.
7. Local codes may take precedence.
8. Data containing information on two circuits shown as follows: circuit 1/circuit 2.
9. Standard condensing temperature option refers to entering condenser water temperatures 95°F (35°C) and below.

Table 23. Electrical data – RTWD, 60 Hz, high efficiency, high condensing temperature

Unit Size	Rated Voltage	Unit Wiring				Motor Data		
		Single Point Power - 1 Power Connection		Dual Point Power - 2 Power Connections		RLA	LRA YD	LRA XL
		MCA	MOP	MCA	MOP			
80	200/60/3	263	350	148/144	250/250	115/115	276/276	912/912
	230/60/3	229	300	129/125	225/225	100/100	238/238	786/786
	380/60/3	139	200	78/76	125/125	61/61	138/138	456/456
	460/60/3	114	150	64/63	110/110	50/50	114/114	376/376
	575/60/3	91	125	51/50	90/90	40/40	93/93	308/308
90	200/60/3	319	450	179/175	300/300	140/140	304/304	1003/1003
	230/60/3	278	400	156/153	250/250	122/122	262/262	866/866
	380/60/3	169	225	95/92	150/150	74/74	161/161	530/530
	460/60/3	139	200	78/76	125/125	61/61	131/131	433/433
	575/60/3	112	150	63/61	110/110	49/49	105/105	346/346
100	200/60/3	364	500	179/220	300/350	140/176	304/355	1003/1137
	230/60/3	317	450	156/191	250/300	122/153	262/294	866/942
	380/60/3	192	250	95/116	150/200	74/93	161/177	530/566
	460/60/3	159	225	78/96	125/150	61/77	131/147	433/471
	575/60/3	127	175	63/76	110/125	49/61	105/118	346/377
110	200/60/3	400	500	224/220	400/350	176/176	355/355	1137/1137
	230/60/3	348	500	195/191	300/300	153/153	294/294	942/942
	380/60/3	211	300	118/116	200/200	93/93	177/177	566/566
	460/60/3	175	250	98/96	175/150	77/77	147/147	471/471
	575/60/3	139	175	78/76	125/125	61/61	118/118	377/377
120	200/60/3	436	600	224/256	400/450	176/205	355/419	1137/1368
	230/60/3	380	500	195/224	300/400	153/179	294/367	942/1200
	380/60/3	230	300	118/135	200/225	93/108	177/229	566/747
	460/60/3	191	250	98/113	175/200	77/90	147/184	471/600
	575/60/3	152	200	78/90	125/150	61/72	118/148	377/483
130	200/60/3	N/A	N/A	260/256	450/450	205/205	419/419	1368/1368
	230/60/3	406	500	227/224	400/400	179/179	367/367	1200/1200
	380/60/3	245	350	137/135	225/225	108/108	229/229	747/747
	460/60/3	204	250	114/113	200/200	90/90	184/184	600/600
	575/60/3	163	225	91/90	150/150	72/72	148/148	483/483
150	200/60/3	502	700	261/293	450/500	205/234	419/487	1368/1498
	230/60/3	438	600	228/255	400/450	179/204	367/427	1200/1314
	380/60/3	267	350	138/157	225/250	108/125	229/260	747/801
	460/60/3	220	300	115/128	200/225	90/102	184/212	600/652
	575/60/3	179	250	92/105	150/175	72/84	148/172	483/528
160	200/60/3	531	700	297/293	500/500	234/234	487/487	1498/1498
	230/60/3	463	600	259/255	450/450	204/204	427/427	1314/1314
	380/60/3	284	400	159/157	250/250	125/125	260/260	801/801
	460/60/3	232	300	130/128	225/225	102/102	212/212	652/652
	575/60/3	191	250	107/105	175/175	84/84	172/172	528/528
180	200/60/3	591	800	297/353	500/600	234/282	487/600	1498/1845
	230/60/3	512	700	259/304	450/500	204/243	427/506	1314/1556
	380/60/3	309	450	159/182	250/300	125/145	260/316	801/973
	460/60/3	253	350	130/149	225/250	102/119	212/252	652/774
	575/60/3	207	300	107/122	175/200	84/97	172/205	528/631



Electrical Data

Table 23. Electrical data – RTWD, 60 Hz, high efficiency, high condensing temperature (continued)

Unit Size	Rated Voltage	Unit Wiring				Motor Data		
		Single Point Power - 1 Power Connection		Dual Point Power - 2 Power Connections		RLA	LRA YD	LRA XL
		MCA	MOP	MCA	MOP			
200	200/60/3	621	800	347/343	600/600	274/274	600/600	1845/1845
	230/60/3	551	700	308/304	500/500	243/243	506/506	1556/1556
	380/60/3	327	450	183/180	300/300	144/144	316/316	973/973
	460/60/3	270	350	151/149	250/250	119/119	252/252	774/774
	575/60/3	220	300	123/122	200/200	97/97	205/205	631/631
220	200/60/3	702	1000	357/415	600/700	282/332	600/701	1845/2156
	230/60/3	608	800	308/362	500/600	243/289	506/571	1556/1756
	380/60/3	373	500	184/225	300/400	145/180	316/345	973/1060
	460/60/3	303	400	151/182	250/300	119/145	252/285	774/878
	575/60/3	244	350	123/145	200/250	97/116	205/229	631/705
250	200/60/3	752	1000	420/415	700/700	332/332	701/701	2156/2156
	230/60/3	654	800	365/362	600/600	289/289	571/571	1756/1756
	380/60/3	408	500	228/225	400/400	180/180	345/345	1060/1060
	460/60/3	329	450	184/182	300/300	145/145	285/285	878/878
	575/60/3	263	350	147/145	250/250	116/116	229/229	705/705

Notes:

1. Voltage Utilization Range: +/- 10% of rated voltage
Rated voltage (use range): 208/60/3 (187.2-228.8), 230/60/3(208-254), 380/60/3 (342-418), 460/60/3 (414-506), 575/60/3 (516-633)MCA–minimum circuit ampacity
2. MOP–maximum overcurrent protection
3. RLA–rated load amps are rated in accordance with UL Standard 1995.
4. LRA–locked rotor amps are based on full winding starts.
5. LRA YD–Locked Rotor Amps in Wye configuration. LRA XL–Locked Rotor Amps in the Delta configuration.
6. Local codes may take precedence.
7. Data containing information on two circuits shown as follows: circuit 1/circuit 2.
8. High condensing temperature option refers to entering condenser water temperatures above 95°F (35°C).

Table 24. Electrical data – RTWD, 60 Hz, premium efficiency, high condensing temperature

Unit Size	Rated Voltage	Unit Wiring				Motor Data		
		Single Point Power - 1 Power Connection		Dual Point Power - 2 Power Connections		RLA	LRA YD	LRA XL
		MCA	MOP	MCA	MOP			
150	200/60/3	498	700	252/295	400/500	198/236	419/487	1368/1498
	230/60/3	430	600	219/254	350/450	172/203	367/427	1200/1314
	380/60/3	266	350	138/155	225/250	108/124	229/260	747/801
	460/60/3	218	300	112/128	175/225	88/102	184/212	600/652
	575/60/3	178	250	91/105	150/175	71/84	148/172	483/528
160	200/60/3	536	700	300/295	500/500	236/236	487/487	1498
	230/60/3	461	600	258/254	450/450	203/203	427/427	1314/1314
	380/60/3	282	400	158/155	250/250	124/124	260/260	801/801
	460/60/3	232	300	130/128	225/225	102/102	212/212	652/652
	575/60/3	191	250	107/105	175/175	84/84	172/172	528/528
180	200/60/3	583	800	300/343	500/600	236/274	487/600	1498/1845
	230/60/3	511	700	258/304	450/500	203/243	427/506	1314/1556
	380/60/3	307	450	158/180	250/300	124/144	260/316	801/973
	460/60/3	253	350	130/149	225/250	102/119	212/252	652/774
	575/60/3	207	300	107/122	175/200	84/97	172/205	528/631
200	200/60/3	621	800	347/343	600/600	274/274	600/600	1845/1845
	230/60/3	551	700	308/304	500/500	243/243	506/506	1556/1556
	380/60/3	327	450	183/180	300/300	144/144	316/316	973/973
	460/60/3	270	350	151/149	250/250	119/119	252/252	774/774
	575/60/3	220	300	123/122	200/200	97/97	205/205	631/631

Notes:

1. Voltage Utilization Range: +/- 10% of rated voltage
Rated voltage (use range): 208/60/3 (187.2-228.8), 230/60/3(208-254), 380/60/3 (342-418), 460/60/3 (414-506), 575/60/3 (516-633)
2. MCA—minimum circuit ampacity
3. MOP—maximum overcurrent protection
4. RLA—rated load amps are rated in accordance with UL Standard 1995.
5. LRA—locked rotor amps are based on full winding starts.
6. LRA YD—Locked Rotor Amps in Wye configuration. LRA XL—Locked Rotor Amps in the Delta configuration.
7. Local codes may take precedence.
8. Data containing information on two circuits shown as follows: circuit 1/circuit 2.
9. High condensing temperature option refers to entering condenser water temperatures above 95°F (35°C).



Electrical Data

Table 25. Electrical data – RTUD, 60 Hz

Unit Size	Rated Voltage	Unit Wiring				Motor Data		
		Single Point Power - 1 Power Connection		Dual Point Power - 2 Power Connections		RLA	LRA YD	LRA XL
		MCA	MOP	MCA	MOP			
80	200/60/3	297	400	167/163	250/250	130/130	276/276	912/912
	230/60/3	261	350	147/143	250/250	114/114	238/238	786/786
	380/60/3	158	225	89/87	150/150	69/69	138/138	456/456
	460/60/3	131	175	74/72	125/125	57/57	114/114	376/376
	575/60/3	105	150	59/58	100/100	46/46	93/93	308/308
90	200/60/3	353	500	198/194	350/300	155/155	304/304	1003/1003
	230/60/3	299	400	168/164	250/250	131/131	262/262	866/866
	380/60/3	185	250	104/102	175/175	81/81	161/161	530/530
	460/60/3	153	200	86/84	150/150	67/67	131/131	433/433
	575/60/3	123	175	69/68	110/110	54/54	105/105	346/346
100	200/60/3	400	500	198/240	350/400	155/192	304/355	1003/1137
	230/60/3	344	500	168/209	250/350	131/167	262/294	866/942
	380/60/3	210	300	104/127	175/225	81/101	161/177	530/566
	460/60/3	174	250	86/105	150/175	67/84	131/147	433/471
	575/60/3	140	200	69/84	110/150	54/67	105/118	346/377
110	200/60/3	437	600	245/240	400/400	192/192	355/355	1137/1137
	230/60/3	380	500	213/209	350/350	167/167	294/294	942/942
	380/60/3	230	300	129/127	225/225	101/101	177/177	566/566
	460/60/3	191	250	107/105	175/175	84/84	147/147	471/471
	575/60/3	153	200	86/84	150/150	67/67	118/118	377/377
120	200/60/3	447	600	245/250	400/450	192/200	355/419	1137/1368
	230/60/3	421	600	213/250	350/450	167/200	294/367	942/1200
	380/60/3	255	350	129/152	225/250	101/121	177/229	566/747
	460/60/3	211	300	107/125	175/225	84/100	147/184	471/600
	575/60/3	169	225	86/100	150/175	67/80	118/148	377/483
130	200/60/3	455	600	255/250	450/450	200/200	419/419	1368/1368
	230/60/3	454	600	254/250	450/450	200/200	367/367	1200/1200
	380/60/3	275	350	154/152	250/250	121/121	229/229	747/747
	460/60/3	227	300	127/125	225/225	100/100	184/184	600/600
	575/60/3	182	250	102/100	175/175	80/80	148/148	483/483
150	200/60/3	542	800	255/338	450/600	200/270	419/487	1368/1498
	230/60/3	498	700	254/294	450/500	200/235	367/427	1200/1314
	380/60/3	301	400	154/178	250/300	121/142	229/260	747/801
	460/60/3	250	350	127/148	225/250	100/118	184/212	600/652
	575/60/3	199	250	102/118	175/200	80/84	148/172	483/528
160	200/60/3	612	800	342/338	600/600	270/270	487/487	1498/1498
	230/60/3	553	700	298/294	500/500	235/235	427/427	1314/1314
	380/60/3	322	450	180/178	300/300	142/142	260/260	801/801
	460/60/3	268	350	150/148	250/250	118/118	212/212	652/652
	575/60/3	213	300	119/118	200/200	94/94	172/172	528/528
180	200/60/3	675	800	342/400	600/700	270/320	487/600	1498/1845
	230/60/3	587	800	298/348	500/600	235/278	427/506	1314/1556
	380/60/3	355	500	180/210	300/350	142/168	260/316	801/973
	460/60/3	284	400	150/164	250/250	118/131	212/252	652/774
	575/60/3	235	300	119/139	200/225	94/111	172/205	528/631

Table 25. Electrical data – RTUD, 60 Hz (continued)

Unit Size	Rated Voltage	Unit Wiring				Motor Data		
		Single Point Power - 1 Power Connection		Dual Point Power - 2 Power Connections		RLA	LRA YD	LRA XL
		MCA	MOP	MCA	MOP			
200	200/60/3	725	1000	405/400	700/700	320/320	600/600	1845/1845
	230/60/3	630	800	352/345	600/600	278/278	506/506	1556/1556
	380/60/3	381	500	213/210	350/350	168/168	316/316	973/973
	460/60/3	297	400	166/164	250/250	131/131	252/252	774/774
	575/60/3	252	350	141/139	250/225	111/111	205/205	631/631
220	200/60/3	743	1000	405/419	700/700	320/335	600/701	1845/2156
	230/60/3	701	1000	352/419	600/700	278/335	506/571	1556/1756
	380/60/3	424	600	213/254	350/450	168/203	316/345	973/1060
	460/60/3	343	500	166/210	250/350	131/168	252/285	774/878
	575/60/3	277	400	141/164	250/250	111/131	205/229	631/705
250	200/60/3	758	1000	423/419	700/700	335/335	701/701	2156/2156
	230/60/3	758	1000	423/419	700/700	335/335	571/571	1756/1756
	380/60/3	459	600	256/254	450/450	203/203	345/345	1060/1060
	460/60/3	380	500	212/210	350/350	168/168	285/285	878/878
	575/60/3	297	400	166/164	250/250	131/131	229/229	705/705

Notes:

1. Voltage Utilization Range: +/- 10% of rated voltage
Rated voltage (use range): 208/60/3 (187.2-228.8), 230/60/3(208-254), 380/60/3 (342-418), 460/60/3 (414-506), 575/60/3 (516-633)MCA–minimum circuit ampacity
2. MOP–maximum overcurrent protection
3. RLA–rated load amps are rated in accordance with UL Standard 1995.
4. LRA–locked rotor amps are based on full winding starts.
5. LRA YD–Locked Rotor Amps in Wye configuration. LRA XL–Locked Rotor Amps in the Delta configuration.
6. Local codes may take precedence.
7. Data containing information on two circuits shown as follows: circuit 1/circuit 2.



Electrical Data

Table 26. Electrical data – Trane air-cooled condenser, 60 Hz

Unit Size	Rated Voltage	Standard Ambient			Low Ambient		
		Fan FLA	Fan MCA	Fan MOP	Fan FLA	Fan MCA	Fan MOP
RTUD 80	208-230/60/3	6	37.5	40	6	37.5	40
	460/60/3	3	18.8	20	3	18.8	20
	575/60/3	2.5	15.6	15	2.5	16.8	15
RTUD 90	208-230/60/3	6	49.5	50	6	49.5	50
	460/60/3	3	24.8	25	3	24.8	25
	575/60/3	2.5	20.6	20	2.5	21.8	20
RTUD 100	208-230/60/3	6	49.5	50	6	49.5	50
	460/60/3	3	24.8	25	3	24.8	25
	575/60/3	2.5	20.6	20	2.5	21.8	20
RTUD 110	208-230/60/3	6	49.5	50	6	49.5	50
	460/60/3	3	24.8	25	3	24.8	25
	575/60/3	2.5	20.6	20	2.5	21.8	20
RTUD 120	208-230/60/3	6	61.5	60	6	61.5	60
	460/60/3	3	30.8	30	3	30.8	30
	575/60/3	2.5	18.8	25	2.5	24.8	25
RTUD 130	208-230/60/3	6	61.5	60	6	61.5	60
	460/60/3	3	30.8	30	3	30.8	30
	575/60/3	2.5	18.8	25	2.5	24.8	25
RTUD 150	208-230/60/3	6	37.5	40	6	37.5	40
	460/60/3	3	18.8	20	3	18.8	20
	575/60/3	2.5	15.6	15	2.5	16.8	15
RTUD 160	208-230/60/3	6	37.5	40	6	37.5	40
	460/60/3	3	18.8	20	3	18.8	20
	575/60/3	2.5	15.6	15	2.5	16.8	15
RTUD 180	208-230/60/3	6	37.5/49.5	40/50	6	37.5/49.5	40/50
	460/60/3	3	18.8/24.8	20/25	3	18.8/24.8	20/25
	575/60/3	2.5	15.6/20.6	15/20	2.5	16.8/21.8	15/20
RTUD 200	208-230/60/3	6	49.5	50	6	49.5	50
	460/60/3	3	24.8	25	3	24.8	25
	575/60/3	2.5	20.6	20	2.5	21.8	20
RTUD 220	208-230/60/3	6	49.5	50	6	49.5	50
	460/60/3	3	24.8	25	3	24.8	25
	575/60/3	2.5	20.6	20	2.5	21.8	20
RTUD 250	208-230/60/3	6	49.5	50	6	49.5	50
	460/60/3	3	24.8	25	3	24.8	25
	575/60/3	2.5	20.6	20	2.5	21.8	20

Notes:

1. MCA–minimum circuit ampacity
2. MOP–maximum overcurrent protection
3. FLA–fan rated load amps
4. Local codes may take precedence.
5. Information is the same for both circuits unless it is shown as: circuit 1/circuit 2.

Customer Wire Selection

Single Point Power

Table 27. Customer wire selection — RTWD, 60Hz, single point power, standard efficiency, standard condensing temperature

Unit Size	Voltage	Terminal Block	Disconnect	Circuit Breaker	
				Standard	Hi Fault
80	200	4-500	1-250	(2) 1-250	(2) 2/0-500
	230	4-500	3/0-350	3/0-350	3/0-350
	380	14-2/0	3/0-350	4-4/0	4-4/0
	460	14-2/0	3/0-350	8-3/0	8-3/0
	575	14-2/0	3/0-350	10-1/0	8-3/0
90	200	4-500	1-250	(2) 2/0-500	(2) 2/0-500
	230	4-500	1-250	(2) 1-250	(2) 2/0-500
	380	14-2/0	3/0-350	4-4/0	4-4/0
	460	14-2/0	3/0-350	4-4/0	4-4/0
	575	14-2/0	3/0-350	8-3/0	8-3/0
100	200	4-500	1-250	(2) 2/0-500	(2) 2/0-500
	230	4-500	1-250	(2) 2/0-500	(2) 2/0-500
	380	4-500	3/0-350	3/0-350	3/0-350
	460	14-2/0	3/0-350	4-4/0	4-4/0
	575	14-2/0	3/0-350	4-4/0	4-4/0
110	200	4-500	(2) 2/0-500	(2) 2/0-500	(2) 2/0-500
	230	4-500	1-250	(2) 2/0-500	(2) 2/0-500
	380	4-500	3/0-350	3/0-350	3/0-350
	460	14-2/0	3/0-350	3/0-350	3/0-350
	575	14-2/0	3/0-350	4-4/0	4-4/0
120	200	(2) 4-500	(2) 2/0-500	(2) 2/0-500	(2) 2/0-500
	230	4-500	(2) 2/0-500	(2) 2/0-500	(2) 2/0-500
	380	4-500	3/0-350	3/0-350	3/0-350
	460	4-500	3/0-350	3/0-350	3/0-350
	575	14-2/0	3/0-350	4-4/0	4-4/0
130	200	(2) 4-500	(2) 2/0-500	(2) 2/0-500	(2) 2/0-500
	230	4-500	(2) 2/0-500	(2) 2/0-500	(2) 2/0-500
	380	4-500	3/0-350	3/0-350	3/0-350
	460	4-500	3/0-350	3/0-350	3/0-350
	575	14-2/0	3/0-350	4-4/0	4-4/0
140	200	(2) 4-500	(2) 2/0-500	(2) 2/0-500	(2) 2/0-500
	230	(2) 4-500	(2) 2/0-500	(2) 2/0-500	(2) 2/0-500
	380	4-500	1-250	(2) 1-250	(2) 2/0-500
	460	4-500	3/0-350	3/0-350	3/0-350
	575	4-500	3/0-350	3/0-350	3/0-350

Notes:

1. Optional non-fused disconnect and circuit breaker.
2. Copper wire only, based on nameplate minimum circuit ampacity (MCA).
3. Standard condensing temperature option refers to entering condenser water temperatures 95°F (35°C) and below.



Electrical Data

Table 28. Customer wire selection – RTWD, 60Hz, single point power, high efficiency, standard condensing temperature

Unit Size	Voltage	Terminal Block	Disconnect	Circuit Breaker	
				Standard	Hi Fault
80	200	4-500	1-250	(2) 1-250	(2) 2/0-500
	230	4-500	3/0-350	3/0-350	3/0-350
	380	14-2/0	3/0-350	4-4/0	4-4/0
	460	14-2/0	3/0-350	8-3/0	8-3/0
	575	14-2/0	3/0-350	10-1/0	8-3/0
90	200	4-500	1-250	(2) 2/0-500	(2) 2/0-500
	230	4-500	1-250	(2) 1-250	(2) 2/0-500
	380	14-2/0	3/0-350	4-4/0	4-4/0
	460	14-2/0	3/0-350	4-4/0	4-4/0
	575	14-2/0	3/0-350	8-3/0	8-3/0
100	200	4-500	1-250	(2) 2/0-500	(2) 2/0-500
	230	4-500	1-250	(2) 2/0-500	(2) 2/0-500
	380	4-500	3/0-350	3/0-350	3/0-350
	460	14-2/0	3/0-350	4-4/0	4-4/0
	575	14-2/0	3/0-350	8-3/0	8-3/0
110	200	4-500	(2) 2/0-500	(2) 2/0-500	(2) 2/0-500
	230	4-500	1-250	(2) 2/0-500	(2) 2/0-500
	380	4-500	3/0-350	3/0-350	3/0-350
	460	14-2/0	3/0-350	4-4/0	4-4/0
	575	14-2/0	3/0-350	4-4/0	4-4/0
120	200	4-500	(2) 2/0-500	(2) 2/0-500	(2) 2/0-500
	230	4-500	1-250	(2) 2/0-500	(2) 2/0-500
	380	4-500	3/0-350	3/0-350	3/0-350
	460	4-500	3/0-350	3/0-350	3/0-350
	575	14-2/0	3/0-350	4-4/0	4-4/0
130	200	(2) 4-500	(2) 2/0-500	(2) 2/0-500	(2) 2/0-500
	230	4-500	(2) 2/0-500	(2) 2/0-500	(2) 2/0-500
	380	4-500	3/0-350	3/0-350	3/0-350
	460	4-500	3/0-350	3/0-350	3/0-350
	575	14-2/0	3/0-350	4-4/0	4-4/0
150	200	(2) 4-500	(2) 2/0-500	(2) 2/0-500	(2) 2/0-500
	230	(2) 4-500	(2) 2/0-500	(2) 2/0-500	(2) 2/0-500
	380	4-500	1-250	(2) 1-250	(2) 2/0-500
	460	4-500	3/0-350	3/0-350	3/0-350
	575	14-2/0	3/0-350	3/0-350	3/0-350
160	200	(2) 4-500	(2) 2/0-500	(2) 2/0-500	(2) 2/0-500
	230	(2) 4-500	(2) 2/0-500	(2) 2/0-500	(2) 2/0-500
	380	4-500	1-250	(2) 1-250	(2) 2/0-500
	460	4-500	3/0-350	3/0-350	3/0-350
	575	4-500	3/0-350	3/0-350	3/0-350
180	200	(2) 4-500	(3) 3/0-500	(3) 3/0-500	(3) 3/0-500
	230	(2) 4-500	(2) 2/0-500	(2) 2/0-500	(2) 2/0-500
	380	4-500	1-250	(2) 2/0-500	(2) 2/0-500
	460	4-500	1-250	(2) 1-250	(2) 2/0-500
	575	4-500	3/0-350	3/0-350	3/0-350

Table 28. Customer wire selection – RTWD, 60Hz, single point power, high efficiency, standard condensing temperature (continued)

Unit Size	Voltage	Terminal Block	Disconnect	Circuit Breaker	
				Standard	Hi Fault
200	200	(2) 4-500	(3) 3/0-500	(3) 3/0-500	(3) 3/0-500
	230	(2) 4-500	(2) 2/0-500	(2) 2/0-500	(2) 2/0-500
	380	4-500	1-250	(2) 2/0-500	(2) 2/0-500
	460	4-500	1-250	(2) 1-250	(2) 2/0-500
	575	4-500	3/0-350	3/0-350	3/0-350
220	200	(2) 4-500	(3) 3/0-500	(3) 3/0-500	(3) 3/0-500
	230	(2) 4-500	(3) 3/0-500	(3) 3/0-500	(3) 3/0-500
	380	4-500	(2) 2/0-500	(2) 2/0-500	(2) 2/0-500
	460	4-500	1-250	(2) 2/0-500	(2) 2/0-500
	575	4-500	1-250	(2) 1-250	(2) 2/0-500
250	200	(2) 4-500	(3) 3/0-500	(3) 3/0-500	(3) 3/0-500
	230	(2) 4-500	(3) 3/0-500	(3) 3/0-500	(3) 3/0-500
	380	4-500	(2) 2/0-500	(2) 2/0-500	(2) 2/0-500
	460	4-500	1-250	(2) 2/0-500	(2) 2/0-500
	575	4-500	1-250	(2) 1-250	(2) 2/0-500

Notes:

1. Optional non-fused disconnect and circuit breaker.
2. Copper wire only, based on nameplate minimum circuit ampacity (MCA).
3. Standard condensing temperature option refers to entering condenser water temperatures 95°F (35°C) and below.



Electrical Data

Table 29. Customer wire selection — RTWD, 60Hz, single point power, premium efficiency, standard condensing temperature

Unit Size	Voltage	Terminal Block	Disconnect	Circuit Breaker	
				Standard	Hi Fault
150	200	(2) 4-500	(2) 2/0-500	(2) 2/0-500	(2) 2/0-500
	230	(2) 4-500	(2) 2/0-500	(2) 2/0-500	(2) 2/0-500
	380	4-500	1-250	(2) 1-250	(2) 2/0-500
	460	4-500	3/0-350	3/0-350	3/0-350
	575	14-2/0	3/0-350	3/0-350	3/0-350
160	200	(2) 4-500	(2) 2/0-500	(2) 2/0-500	(2) 2/0-500
	230	(2) 4-500	(2) 2/0-500	(2) 2/0-500	(2) 2/0-500
	380	4-500	1-250	(2) 1-250	(2) 2/0-500
	460	4-500	3/0-350	3/0-350	3/0-350
	575	4-500	3/0-350	3/0-350	3/0-350
180	200	(2) 4-500	(3) 3/0-500	(3) 3/0-500	(3) 3/0-500
	230	(2) 4-500	(2) 2/0-500	(2) 2/0-500	(2) 2/0-500
	380	4-500	1-250	(2) 2/0-500	(2) 2/0-500
	460	4-500	1-250	(2) 1-250	(2) 2/0-500
	575	4-500	3/0-350	3/0-350	3/0-350
200	200	(2) 4-500	(3) 3/0-500	(3) 3/0-500	(3) 3/0-500
	230	(2) 4-500	(2) 2/0-500	(2) 2/0-500	(2) 2/0-500
	380	4-500	1-250	(2) 2/0-500	(2) 2/0-500
	460	4-500	1-250	(2) 1-250	(2) 2/0-500
	575	4-500	3/0-350	3/0-350	3/0-350

Notes:

1. Optional non-fused disconnect and circuit breaker.
2. Copper wire only, based on nameplate minimum circuit ampacity (MCA).
3. Standard condensing temperature option refers to entering condenser water temperatures 95°F (35°C) and below.

Table 30. Customer wire selection – RTWD, 60Hz, single point power, high efficiency, high condensing temperature

Unit Size	Voltage	Terminal Block	Disconnect	Circuit Breaker	
				Standard	Hi Fault
80	200	4-500	1-250	(2) 2/0-500	(2) 2/0-500
	230	4-500	1-250	(2) 1-250	(2) 2/0-500
	380	14-2/0	3/0-350	3/0-350	3/0-350
	460	14-2/0	3/0-350	-	-
	575	14-2/0	3/0-350	8-3/0	8-3/0
90	200	4-500	(2) 2/0-500	(2) 2/0-500	(2) 2/0-500
	230	4-500	1-250	(2) 2/0-500	(2) 2/0-500
	380	4-500	3/0-350	3/0-350	3/0-350
	460	14-2/0	3/0-350	3/0-350	3/0-350
	575	14-2/0	3/0-350	4-4/0	4-4/0
100	200	(2) 4-500	(2) 2/0-500	(2) 2/0-500	(2) 2/0-500
	230	4-500	(2) 2/0-500	(2) 2/0-500	(2) 2/0-500
	380	4-500	3/0-350	3/0-350	3/0-350
	460	4-500	3/0-350	3/0-350	3/0-350
	575	14-2/0	3/0-350	4-4/0	4-4/0
110	200	(2) 4-500	(2) 2/0-500	(2) 2/0-500	(2) 2/0-500
	230	4-500	(2) 2/0-500	(2) 2/0-500	(2) 2/0-500
	380	4-500	1-250	(2) 1-250	(2) 2/0-500
	460	4-500	3/0-350	3/0-350	3/0-350
	575	14-2/0	3/0-350	-	-
120	200	(2) 4-500	(2) 2/0-500	(2) 2/0-500	(2) 2/0-500
	230	(2) 4-500	(2) 2/0-500	(2) 2/0-500	(2) 2/0-500
	380	4-500	1-250	(2) 1-250	(2) 2/0-500
	460	4-500	3/0-350	3/0-350	3/0-350
	575	4-500	3/0-350	3/0-350	3/0-350
130	200	-	-	-	-
	230	(2) 4-500	(2) 2/0-500	(2) 2/0-500	(2) 2/0-500
	380	4-500	1-250	(2) 2/0-500	(2) 2/0-500
	460	4-500	3/0-350	3/0-350	3/0-350
	575	4-500	3/0-350	3/0-350	3/0-350
150	200	(2) 4-500	(3) 3/0-500	(3) 3/0-500	(3) 3/0-500
	230	(2) 4-500	(2) 2/0-500	(2) 2/0-500	(2) 2/0-500
	380	4-500	1-250	(2) 2/0-500	(2) 2/0-500
	460	4-500	1-250	(2) 1-250	(2) 2/0-500
	575	4-500	3/0-350	3/0-350	3/0-350
160	200	(2) 4-500	(3) 3/0-500	(3) 3/0-500	(3) 3/0-500
	230	(2) 4-500	(2) 2/0-500	(2) 2/0-500	(2) 2/0-500
	380	4-500	1-250	(2) 2/0-500	(2) 2/0-500
	460	4-500	1-250	(2) 1-250	(2) 2/0-500
	575	4-500	3/0-350	3/0-350	3/0-350
180	200	(2) 4-500	(3) 3/0-500	(3) 3/0-500	(3) 3/0-500
	230	(2) 4-500	(3) 3/0-500	(3) 3/0-500	(3) 3/0-500
	380	4-500	(2) 2/0-500	(2) 2/0-500	(2) 2/0-500
	460	4-500	1-250	(2) 2/0-500	(2) 2/0-500
	575	4-500	1-250	(2) 1-250	(2) 2/0-500



Electrical Data

Table 30. Customer wire selection — RTWD, 60Hz, single point power, high efficiency, high condensing temperature (continued)

Unit Size	Voltage	Terminal Block	Disconnect	Circuit Breaker	
				Standard	Hi Fault
200	200	(2) 4-500	(3) 3/0-500	(3) 3/0-500	(3) 3/0-500
	230	(2) 4-500	(3) 3/0-500	(3) 3/0-500	(3) 3/0-500
	380	4-500	(2) 2/0-500	(2) 2/0-500	(2) 2/0-500
	460	4-500	1-250	(2) 2/0-500	(2) 2/0-500
	575	4-500	1-250	(2) 1-250	(2) 2/0-500
220	200	(2) 4-500	(3) 3/0-500	(4) 3/0-500	(4) 3/0-500
	230	(2) 4-500	(3) 3/0-500	(3) 3/0-500	(3) 3/0-500
	380	(2) 4-500	(2) 2/0-500	(2) 2/0-500	(2) 2/0-500
	460	4-500	1-250	(2) 2/0-500	(2) 2/0-500
	575	4-500	1-250	(2) 2/0-500	(2) 2/0-500
250	200	(2) 4-500	(3) 3/0-500	(4) 3/0-500	(4) 3/0-500
	230	(2) 4-500	(3) 3/0-500	(3) 3/0-500	(3) 3/0-500
	380	(2) 4-500	(2) 2/0-500	(2) 2/0-500	(2) 2/0-500
	460	4-500	(2) 2/0-500	(2) 2/0-500	(2) 2/0-500
	575	4-500	1-250	(2) 2/0-500	(2) 2/0-500

Notes:

1. Optional non-fused disconnect and circuit breaker.
2. Copper wire only, based on nameplate minimum circuit ampacity (MCA).
3. High condensing temperature option refers to entering condenser water temperatures above 95°F (35°C).

Table 31. Customer wire selection — RTWD, 60Hz, single point power, premium efficiency, high condensing temperature

Unit Size	Voltage	Terminal Block	Disconnect	Circuit Breaker	
				Standard	Hi Fault
150	200	(2) 4-500	(3) 3/0-500	(3) 3/0-500	(3) 3/0-500
	230	(2) 4-500	(2) 2/0-500	(2) 2/0-500	(2) 2/0-500
	380	4-500	1-250	(2) 2/0-500	(2) 2/0-500
	460	4-500	1-250	(2) 1-250	(2) 2/0-500
	575	4-500	3/0-350	3/0-350	3/0-350
160	200	(2) 4-500	(3) 3/0-500	(3) 3/0-500	(3) 3/0-500
	230	(2) 4-500	(2) 2/0-500	(2) 2/0-500	(2) 2/0-500
	380	4-500	1-250	(2) 2/0-500	(2) 2/0-500
	460	4-500	1-250	(2) 1-250	(2) 2/0-500
	575	4-500	3/0-350	3/0-350	3/0-350
180	200	(2) 4-500	(3) 3/0-500	(3) 3/0-500	(3) 3/0-500
	230	(2) 4-500	(3) 3/0-500	(3) 3/0-500	(3) 3/0-500
	380	4-500	(2) 2/0-500	(2) 2/0-500	(2) 2/0-500
	460	4-500	1-250	(2) 2/0-500	(2) 2/0-500
	575	4-500	1-250	(2) 1-250	(2) 2/0-500
200	200	(2) 4-500	(3) 3/0-500	(3) 3/0-500	(3) 3/0-500
	230	(2) 4-500	(3) 3/0-500	(3) 3/0-500	(3) 3/0-500
	380	4-500	(2) 2/0-500	(2) 2/0-500	(2) 2/0-500
	460	4-500	1-250	(2) 2/0-500	(2) 2/0-500
	575	4-500	1-250	(2) 1-250	(2) 2/0-500

Notes:

1. Optional non-fused disconnect and circuit breaker.
2. Copper wire only, based on nameplate minimum circuit ampacity (MCA).
3. High condensing temperature option refers to entering condenser water temperatures above 95°F (35°C).

Table 32. Customer wire selection – RTUD, 60Hz, single point power

Unit Size	Voltage	Terminal Block	Disconnect	Circuit Breaker	
				Standard	Hi Fault
80	200	4-500	1-250	(2) 2/0-500	(2) 2/0-500
	230	4-500	1-250	(2) 2/0-500	(2) 2/0-500
	380	4-500	3/0-350	3/0-350	3/0-350
	460	14-2/0	3/0-350	4-4/0	4-4/0
	575	14-2/0	3/0-350	4-4/0	4-4/0
90	200	(2) 4-500	(2) 2/0-500	(2) 2/0-500	(2) 2/0-500
	230	4-500	1-250	(2) 2/0-500	(2) 2/0-500
	380	4-500	3/0-350	3/0-350	3/0-350
	460	4-500	3/0-350	3/0-350	3/0-350
	575	14-2/0	3/0-350	4-4/0	4-4/0
100	200	(2) 4-500	(2) 2/0-500	(2) 2/0-500	(2) 2/0-500
	230	4-500	(2) 2/0-500	(2) 2/0-500	(2) 2/0-500
	380	4-500	1-250	(2) 1-250	(2) 2/0-500
	460	4-500	3/0-350	3/0-350	3/0-350
	575	14-2/0	3/0-350	3/0-350	3/0-350
110	200	(2) 4-500	(2) 2/0-500	(2) 2/0-500	(2) 2/0-500
	230	(2) 4-500	(2) 2/0-500	(2) 2/0-500	(2) 2/0-500
	380	4-500	1-250	(2) 1-250	(2) 2/0-500
	460	4-500	3/0-350	3/0-350	3/0-350
	575	4-500	3/0-350	3/0-350	3/0-350
120	200	(2) 4-500	(2) 2/0-500	(2) 2/0-500	(2) 2/0-500
	230	(2) 4-500	(2) 2/0-500	(2) 2/0-500	(2) 2/0-500
	380	4-500	1-250	(2) 2/0-500	(2) 2/0-500
	460	4-500	1-250	(2) 1-250	(2) 2/0-500
	575	4-500	3/0-350	3/0-350	3/0-350
130	200	(2) 4-500	(2) 2/0-500	(2) 2/0-500	(2) 2/0-500
	230	(2) 4-500	(2) 2/0-500	(2) 2/0-500	(2) 2/0-500
	380	4-500	1-250	(2) 2/0-500	(2) 2/0-500
	460	4-500	1-250	(2) 1-250	(2) 2/0-500
	575	4-500	3/0-350	3/0-350	3/0-350
150	200	(2) 4-500	(3) 3/0-500	(3) 3/0-500	(3) 3/0-500
	230	(2) 4-500	(3) 3/0-500	(3) 3/0-500	(3) 3/0-500
	380	4-500	1-250	(2) 2/0-500	(2) 2/0-500
	460	4-500	1-250	(2) 2/0-500	(2) 2/0-500
	575	4-500	3/0-350	3/0-350	3/0-350
160	200	(2) 4-500	(3) 3/0-500	(3) 3/0-500	(3) 3/0-500
	230	(2) 4-500	(3) 3/0-500	(3) 3/0-500	(3) 3/0-500
	380	4-500	(2) 2/0-500	(2) 2/0-500	(2) 2/0-500
	460	4-500	1-250	(2) 2/0-500	(2) 2/0-500
	575	4-500	1-250	(2) 1-250	(2) 2/0-500
180	200	(2) 4-500	(3) 3/0-500	(3) 3/0-500	(3) 3/0-500
	230	(2) 4-500	(3) 3/0-500	(3) 3/0-500	(3) 3/0-500
	380	(2) 4-500	(2) 2/0-500	(2) 2/0-500	(2) 2/0-500
	460	4-500	1-250	(2) 2/0-500	(2) 2/0-500
	575	4-500	1-250	(2) 1-250	(2) 2/0-500



Electrical Data

Table 32. Customer wire selection – RTUD, 60Hz, single point power (continued)

Unit Size	Voltage	Terminal Block	Disconnect	Circuit Breaker	
				Standard	Hi Fault
200	200	(2) 4-500	(3) 3/0-500	(4) 3/0-500	(4) 3/0-500
	230	(2) 4-500	(3) 3/0-500	(3) 3/0-500	(3) 3/0-500
	380	(2) 4-500	(2) 2/0-500	(2) 2/0-500	(2) 2/0-500
	460	4-500	1-250	(2) 2/0-500	(2) 2/0-500
	575	4-500	1-250	(2) 2/0-500	(2) 2/0-500
220	200	(2) 4-500	(3) 3/0-500	(4) 3/0-500	(4) 3/0-500
	230	(2) 4-500	(3) 3/0-500	(4) 3/0-500	(4) 3/0-500
	380	(2) 4-500	(2) 2/0-500	(2) 2/0-500	(2) 2/0-500
	460	4-500	(2) 2/0-500	(2) 2/0-500	(2) 2/0-500
	575	4-500	1-250	(2) 2/0-500	(2) 2/0-500
250	200	(2) 4-500	(3) 3/0-500	(4) 3/0-500	(4) 3/0-500
	230	(2) 4-500	(3) 3/0-500	(4) 3/0-500	(4) 3/0-500
	380	(2) 4-500	(2) 2/0-500	(2) 2/0-500	(2) 2/0-500
	460	(2) 4-500	(2) 2/0-500	(2) 2/0-500	(2) 2/0-500
	575	4-500	1-250	(2) 2/0-500	(2) 2/0-500

Notes:

1. Optional non-fused disconnect and circuit breaker.
2. Copper wire only, based on nameplate minimum circuit ampacity (MCA).

Dual Point Power

Table 33. Customer wire selection — RTWD, 60Hz, dual point power, standard efficiency, standard condensing temperature

Unit Size	Voltage	Terminal Block		Disconnect		Circuit Breaker		Ckt Brkr - Hi Fault	
		Ckt 1	Ckt 2	Ckt 1	Ckt 2	Ckt 1	Ckt 2	Ckt 1	Ckt 2
80	200	14-2/0	14-2/0	3/0-350	3/0-350	3/0-350	3/0-350	3/0-350	3/0-350
	230	14-2/0	14-2/0	3/0-350	3/0-350	4-4/0	4-4/0	4-4/0	4-4/0
	380	14-2/0	14-2/0	3/0-350	3/0-350	8-3/0	8-3/0	8-3/0	8-3/0
	460	14-2/0	14-2/0	3/0-350	3/0-350	10-1/0	10-1/0	8-3/0	8-3/0
	575	14-2/0	14-2/0	3/0-350	3/0-350	10-1/0	10-1/0	-	-
90	200	14-2/0	14-2/0	3/0-350	3/0-350	3/0-350	3/0-350	3/0-350	3/0-350
	230	14-2/0	14-2/0	3/0-350	3/0-350	3/0-350	3/0-350	3/0-350	3/0-350
	380	14-2/0	14-2/0	3/0-350	3/0-350	8-3/0	8-3/0	8-3/0	8-3/0
	460	14-2/0	14-2/0	3/0-350	3/0-350	10-1/0	10-1/0	8-3/0	8-3/0
	575	14-2/0	14-2/0	3/0-350	3/0-350	10-1/0	10-1/0	8-3/0	8-3/0
100	200	14-2/0	4-500	3/0-350	1-250	3/0-350	(2) 1-250	3/0-350	(2) 2/0-500
	230	14-2/0	4-500	3/0-350	3/0-350	3/0-350	3/0-350	3/0-350	3/0-350
	380	14-2/0	14-2/0	3/0-350	3/0-350	8-3/0	4-4/0	8-3/0	4-4/0
	460	14-2/0	14-2/0	3/0-350	3/0-350	10-1/0	8-3/0	8-3/0	8-3/0
	575	14-2/0	14-2/0	3/0-350	3/0-350	10-1/0	8-3/0	8-3/0	8-3/0
110	200	4-500	4-500	1-250	1-250	(2) 1-250	(2) 1-250	(2) 2/0-500	(2) 2/0-500
	230	4-500	4-500	3/0-350	3/0-350	3/0-350	3/0-350	3/0-350	3/0-350
	380	14-2/0	14-2/0	3/0-350	3/0-350	4-4/0	4-4/0	4-4/0	4-4/0
	460	14-2/0	14-2/0	3/0-350	3/0-350	8-3/0	8-3/0	8-3/0	8-3/0
	575	14-2/0	14-2/0	3/0-350	3/0-350	8-3/0	8-3/0	8-3/0	8-3/0
120	200	4-500	4-500	1-250	1-250	(2) 1-250	(2) 2/0-500	(2) 2/0-500	(2) 2/0-500
	230	4-500	4-500	3/0-350	1-250	3/0-350	(2) 1-250	3/0-350	(2) 2/0-500
	380	14-2/0	14-2/0	3/0-350	3/0-350	4-4/0	4-4/0	4-4/0	4-4/0
	460	14-2/0	14-2/0	3/0-350	3/0-350	8-3/0	4-4/0	8-3/0	4-4/0
	575	14-2/0	14-2/0	3/0-350	3/0-350	8-3/0	8-3/0	8-3/0	8-3/0
130	200	4-500	4-500	1-250	1-250	(2) 2/0-500	(2) 2/0-500	(2) 2/0-500	(2) 2/0-500
	230	4-500	4-500	1-250	1-250	(2) 1-250	(2) 1-250	(2) 2/0-500	(2) 2/0-500
	380	14-2/0	14-2/0	3/0-350	3/0-350	3/0-350	4-4/0	3/0-350	4-4/0
	460	14-2/0	14-2/0	3/0-350	3/0-350	4-4/0	4-4/0	4-4/0	4-4/0
	575	14-2/0	14-2/0	3/0-350	3/0-350	8-3/0	8-3/0	8-3/0	8-3/0
140	200	4-500	4-500	1-250	(2) 2/0-500	(2) 2/0-500	(2) 2/0-500	(2) 2/0-500	(2) 2/0-500
	230	4-500	4-500	1-250	1-250	(2) 1-250	(2) 2/0-500	(2) 2/0-500	(2) 2/0-500
	380	14-2/0	14-2/0	3/0-350	3/0-350	3/0-350	3/0-350	3/0-350	3/0-350
	460	14-2/0	14-2/0	3/0-350	3/0-350	4-4/0	4-4/0	4-4/0	4-4/0
	575	14-2/0	14-2/0	3/0-350	3/0-350	8-3/0	4-4/0	8-3/0	4-4/0

Notes:

1. Optional non-fused disconnect and circuit breaker.
2. Copper wire only, based on nameplate minimum circuit ampacity (MCA).
3. Standard condensing temperature option refers to entering condenser water temperatures 95°F (35°C) and below.



Electrical Data

Table 34. Customer wire selection — RTWD, 60Hz, dual point power, high efficiency, standard condensing temperature

Unit Size	Voltage	Terminal Block		Disconnect		Circuit Breaker		Ckt Brkr - Hi Fault	
		Ckt 1	Ckt 2	Ckt 1	Ckt 2	Ckt 1	Ckt 2	Ckt 1	Ckt 2
80	200	14-2/0	14-2/0	3/0-350	3/0-350	3/0-350	3/0-350	3/0-350	3/0-350
	230	14-2/0	14-2/0	3/0-350	3/0-350	4-4/0	4-4/0	4-4/0	4-4/0
	380	14-2/0	14-2/0	3/0-350	3/0-350	8-3/0	8-3/0	8-3/0	8-3/0
	460	14-2/0	14-2/0	3/0-350	3/0-350	10-1/0	10-1/0	8-3/0	8-3/0
	575	14-2/0	14-2/0	3/0-350	3/0-350	10-1/0	10-1/0	-	-
90	200	14-2/0	14-2/0	3/0-350	3/0-350	3/0-350	3/0-350	3/0-350	3/0-350
	230	14-2/0	14-2/0	3/0-350	3/0-350	3/0-350	3/0-350	3/0-350	3/0-350
	380	14-2/0	14-2/0	3/0-350	3/0-350	8-3/0	8-3/0	8-3/0	8-3/0
	460	14-2/0	14-2/0	3/0-350	3/0-350	10-1/0	10-1/0	8-3/0	8-3/0
	575	14-2/0	14-2/0	3/0-350	3/0-350	10-1/0	10-1/0	8-3/0	8-3/0
100	200	14-2/0	4-500	3/0-350	1-250	3/0-350	(2) 1-250	3/0-350	(2) 2/0-500
	230	14-2/0	4-500	3/0-350	3/0-350	3/0-350	3/0-350	3/0-350	3/0-350
	380	14-2/0	14-2/0	3/0-350	3/0-350	8-3/0	4-4/0	8-3/0	4-4/0
	460	14-2/0	14-2/0	3/0-350	3/0-350	10-1/0	8-3/0	8-3/0	8-3/0
	575	14-2/0	14-2/0	3/0-350	3/0-350	10-1/0	10-1/0	8-3/0	8-3/0
110	200	4-500	4-500	1-250	1-250	(2) 1-250	(2) 1-250	(2) 2/0-500	(2) 2/0-500
	230	4-500	4-500	3/0-350	3/0-350	3/0-350	3/0-350	3/0-350	3/0-350
	380	14-2/0	14-2/0	3/0-350	3/0-350	4-4/0	4-4/0	4-4/0	4-4/0
	460	14-2/0	14-2/0	3/0-350	3/0-350	8-3/0	8-3/0	8-3/0	8-3/0
	575	14-2/0	14-2/0	3/0-350	3/0-350	10-1/0	10-1/0	8-3/0	8-3/0
120	200	4-500	4-500	1-250	1-250	(2) 1-250	(2) 2/0-500	(2) 2/0-500	(2) 2/0-500
	230	4-500	4-500	3/0-350	1-250	3/0-350	(2) 1-250	3/0-350	(2) 2/0-500
	380	14-2/0	14-2/0	3/0-350	3/0-350	4-4/0	4-4/0	4-4/0	4-4/0
	460	14-2/0	14-2/0	3/0-350	3/0-350	8-3/0	4-4/0	8-3/0	4-4/0
	575	14-2/0	14-2/0	3/0-350	3/0-350	10-1/0	8-3/0	8-3/0	8-3/0
130	200	4-500	4-500	1-250	1-250	(2) 2/0-500	(2) 2/0-500	(2) 2/0-500	(2) 2/0-500
	230	4-500	4-500	1-250	1-250	(2) 1-250	(2) 1-250	(2) 2/0-500	(2) 2/0-500
	380	14-2/0	14-2/0	3/0-350	3/0-350	4-4/0	4-4/0	4-4/0	4-4/0
	460	14-2/0	14-2/0	3/0-350	3/0-350	4-4/0	4-4/0	4-4/0	4-4/0
	575	14-2/0	14-2/0	3/0-350	3/0-350	8-3/0	8-3/0	8-3/0	8-3/0
150	200	4-500	4-500	1-250	1-250	(2) 2/0-500	(2) 2/0-500	(2) 2/0-500	(2) 2/0-500
	230	4-500	4-500	1-250	1-250	(2) 1-250	(2) 2/0-500	(2) 2/0-500	(2) 2/0-500
	380	14-2/0	14-2/0	3/0-350	3/0-350	4-4/0	3/0-350	4-4/0	3/0-350
	460	14-2/0	14-2/0	3/0-350	3/0-350	4-4/0	4-4/0	4-4/0	4-4/0
	575	14-2/0	14-2/0	3/0-350	3/0-350	8-3/0	4-4/0	8-3/0	4-4/0
160	200	4-500	4-500	1-250	1-250	(2) 2/0-500	(2) 2/0-500	(2) 2/0-500	(2) 2/0-500
	230	4-500	4-500	1-250	1-250	(2) 2/0-500	(2) 2/0-500	(2) 2/0-500	(2) 2/0-500
	380	14-2/0	14-2/0	3/0-350	3/0-350	3/0-350	3/0-350	3/0-350	3/0-350
	460	14-2/0	14-2/0	3/0-350	3/0-350	4-4/0	4-4/0	4-4/0	4-4/0
	575	14-2/0	14-2/0	3/0-350	3/0-350	4-4/0	4-4/0	4-4/0	4-4/0
180	200	4-500	4-500	1-250	(2) 2/0-500	(2) 2/0-500	(2) 2/0-500	(2) 2/0-500	(2) 2/0-500
	230	4-500	4-500	1-250	1-250	(2) 2/0-500	(2) 2/0-500	(2) 2/0-500	(2) 2/0-500
	380	14-2/0	4-500	3/0-350	3/0-350	3/0-350	3/0-350	3/0-350	3/0-350
	460	14-2/0	14-2/0	3/0-350	3/0-350	4-4/0	3/0-350	4-4/0	3/0-350
	575	14-2/0	14-2/0	3/0-350	3/0-350	4-4/0	4-4/0	4-4/0	4-4/0

Table 34. Customer wire selection — RTWD, 60Hz, dual point power, high efficiency, standard condensing temperature (continued)

Unit Size	Voltage	Terminal Block		Disconnect		Circuit Breaker		Ckt Brkr - Hi Fault	
		Ckt 1	Ckt 2	Ckt 1	Ckt 2	Ckt 1	Ckt 2	Ckt 1	Ckt 2
200	200	4-500	4-500	(2) 2/0-500	(2) 2/0-500	(2) 2/0-500	(2) 2/0-500	(2) 2/0-500	(2) 2/0-500
	230	4-500	4-500	1-250	1-250	(2) 2/0-500	(2) 2/0-500	(2) 2/0-500	(2) 2/0-500
	380	4-500	4-500	3/0-350	3/0-350	3/0-350	3/0-350	3/0-350	3/0-350
	460	14-2/0	14-2/0	3/0-350	3/0-350	3/0-350	3/0-350	3/0-350	3/0-350
	575	14-2/0	14-2/0	3/0-350	3/0-350	4-4/0	4-4/0	4-4/0	4-4/0
220	200	4-500	(2) 4-500	(2) 2/0-500	(2) 2/0-500	(2) 2/0-500	(2) 2/0-500	(2) 2/0-500	(2) 2/0-500
	230	4-500	4-500	1-250	(2) 2/0-500	(2) 2/0-500	(2) 2/0-500	(2) 2/0-500	(2) 2/0-500
	380	4-500	4-500	3/0-350	1-250	3/0-350	(2) 1-250	3/0-350	(2) 2/0-500
	460	14-2/0	4-500	3/0-350	3/0-350	3/0-350	3/0-350	3/0-350	3/0-350
	575	14-2/0	14-2/0	3/0-350	3/0-350	4-4/0	3/0-350	4-4/0	3/0-350
250	200	(2) 4-500	(2) 4-500	(2) 2/0-500	(2) 2/0-500	(2) 2/0-500	(2) 2/0-500	(2) 2/0-500	(2) 2/0-500
	230	4-500	4-500	(2) 2/0-500	(2) 2/0-500	(2) 2/0-500	(2) 2/0-500	(2) 2/0-500	(2) 2/0-500
	380	4-500	4-500	1-250	1-250	(2) 1-250	(2) 1-250	(2) 2/0-500	(2) 2/0-500
	460	4-500	4-500	3/0-350	3/0-350	3/0-350	3/0-350	3/0-350	3/0-350
	575	14-2/0	14-2/0	3/0-350	3/0-350	3/0-350	3/0-350	3/0-350	3/0-350

Notes:

1. Optional non-fused disconnect and circuit breaker.
2. Copper wire only, based on nameplate minimum circuit ampacity (MCA).
3. Standard condensing temperature option refers to entering condenser water temperatures 95°F (35°C) and below.

Table 35. Customer wire selection — RTWD, 60Hz, dual point power, premium efficiency, standard condensing temperature

Unit Size	Voltage	Terminal Block		Disconnect		Circuit Breaker		Ckt Brkr - Hi Fault	
		Ckt 1	Ckt 2	Ckt 1	Ckt 2	Ckt 1	Ckt 2	Ckt 1	Ckt 2
150	200	4-500	4-500	1-250	1-250	(2) 2/0-500	(2) 2/0-500	(2) 2/0-500	(2) 2/0-500
	230	4-500	4-500	1-250	1-250	(2) 1-250	(2) 2/0-500	(2) 2/0-500	(2) 2/0-500
	380	14-2/0	14-2/0	3/0-350	3/0-350	4-4/0	3/0-350	4-4/0	3/0-350
	460	14-2/0	14-2/0	3/0-350	3/0-350	4-4/0	4-4/0	4-4/0	4-4/0
	575	14-2/0	14-2/0	3/0-350	3/0-350	8-3/0	4-4/0	8-3/0	4-4/0
160	200	4-500	4-500	1-250	1-250	(2) 2/0-500	(2) 2/0-500	(2) 2/0-500	(2) 2/0-500
	230	4-500	4-500	1-250	1-250	(2) 2/0-500	(2) 2/0-500	(2) 2/0-500	(2) 2/0-500
	380	14-2/0	14-2/0	3/0-350	3/0-350	3/0-350	3/0-350	3/0-350	3/0-350
	460	14-2/0	14-2/0	3/0-350	3/0-350	4-4/0	4-4/0	4-4/0	4-4/0
	575	14-2/0	14-2/0	3/0-350	3/0-350	4-4/0	4-4/0	4-4/0	4-4/0
180	200	4-500	4-500	1-250	(2) 2/0-500	(2) 2/0-500	(2) 2/0-500	(2) 2/0-500	(2) 2/0-500
	230	4-500	4-500	1-250	1-250	(2) 2/0-500	(2) 2/0-500	(2) 2/0-500	(2) 2/0-500
	380	14-2/0	4-500	3/0-350	3/0-350	3/0-350	3/0-350	3/0-350	3/0-350
	460	14-2/0	14-2/0	3/0-350	3/0-350	4-4/0	3/0-350	4-4/0	3/0-350
	575	14-2/0	14-2/0	3/0-350	3/0-350	4-4/0	4-4/0	4-4/0	4-4/0
200	200	4-500	4-500	(2) 2/0-500	(2) 2/0-500	(2) 2/0-500	(2) 2/0-500	(2) 2/0-500	(2) 2/0-500
	230	4-500	4-500	1-250	1-250	(2) 2/0-500	(2) 2/0-500	(2) 2/0-500	(2) 2/0-500
	380	4-500	4-500	3/0-350	3/0-350	3/0-350	3/0-350	3/0-350	3/0-350
	460	14-2/0	14-2/0	3/0-350	3/0-350	3/0-350	3/0-350	3/0-350	3/0-350
	575	14-2/0	14-2/0	3/0-350	3/0-350	4-4/0	4-4/0	4-4/0	4-4/0

Notes:

1. Optional non-fused disconnect and circuit breaker.
2. Copper wire only, based on nameplate minimum circuit ampacity (MCA).
3. Standard condensing temperature option refers to entering condenser water temperatures 95°F (35°C) and below.



Electrical Data

Table 36. Customer wire selection — RTWD, 60Hz, dual point power, high efficiency, high condensing temperature

Unit Size	Voltage	Terminal Block		Disconnect		Circuit Breaker		Ckt Brkr - Hi Fault	
		Ckt 1	Ckt 2	Ckt 1	Ckt 2	Ckt 1	Ckt 2	Ckt 1	Ckt 2
80	200	4-500	14-2/0	3/0-350	3/0-350	3/0-350	3/0-350	3/0-350	3/0-350
	230	14-2/0	14-2/0	3/0-350	3/0-350	3/0-350	3/0-350	3/0-350	3/0-350
	380	14-2/0	14-2/0	3/0-350	3/0-350	8-3/0	8-3/0	8-3/0	8-3/0
	460	14-2/0	14-2/0	3/0-350	3/0-350	8-3/0	8-3/0	8-3/0	8-3/0
	575	14-2/0	14-2/0	3/0-350	3/0-350	10-1/0	10-1/0	8-3/0	8-3/0
90	200	4-500	4-500	1-250	1-250	(2) 1-250	(2) 1-250	(2) 2/0-500	(2) 2/0-500
	230	4-500	4-500	3/0-350	3/0-350	3/0-350	3/0-350	3/0-350	3/0-350
	380	14-2/0	14-2/0	3/0-350	3/0-350	4-4/0	4-4/0	4-4/0	4-4/0
	460	14-2/0	14-2/0	3/0-350	3/0-350	8-3/0	8-3/0	8-3/0	8-3/0
	575	14-2/0	14-2/0	3/0-350	3/0-350	8-3/0	8-3/0	8-3/0	8-3/0
100	200	4-500	4-500	1-250	1-250	(2) 1-250	(2) 2/0-500	(2) 2/0-500	(2) 2/0-500
	230	4-500	4-500	3/0-350	1-250	3/0-350	(2) 1-250	3/0-350	(2) 2/0-500
	380	14-2/0	14-2/0	3/0-350	3/0-350	4-4/0	3/0-350	4-4/0	3/0-350
	460	14-2/0	14-2/0	3/0-350	3/0-350	8-3/0	4-4/0	8-3/0	4-4/0
	575	14-2/0	14-2/0	3/0-350	3/0-350	8-3/0	8-3/0	8-3/0	8-3/0
110	200	4-500	4-500	1-250	1-250	(2) 2/0-500	(2) 2/0-500	(2) 2/0-500	(2) 2/0-500
	230	4-500	4-500	1-250	1-250	(2) 1-250	(2) 1-250	(2) 2/0-500	(2) 2/0-500
	380	14-2/0	14-2/0	3/0-350	3/0-350	3/0-350	3/0-350	3/0-350	3/0-350
	460	14-2/0	14-2/0	3/0-350	3/0-350	4-4/0	4-4/0	4-4/0	4-4/0
	575	14-2/0	14-2/0	3/0-350	3/0-350	8-3/0	8-3/0	8-3/0	8-3/0
120	200	4-500	4-500	1-250	(2) 2/0-500	(2) 2/0-500	(2) 2/0-500	(2) 2/0-500	(2) 2/0-500
	230	4-500	4-500	1-250	1-250	(2) 1-250	(2) 2/0-500	(2) 2/0-500	(2) 2/0-500
	380	14-2/0	14-2/0	3/0-350	3/0-350	3/0-350	3/0-350	3/0-350	3/0-350
	460	14-2/0	14-2/0	3/0-350	3/0-350	4-4/0	3/0-350	4-4/0	3/0-350
	575	14-2/0	14-2/0	3/0-350	3/0-350	8-3/0	4-4/0	8-3/0	4-4/0
130	200	4-500	4-500	(2) 2/0-500	(2) 2/0-500	(2) 2/0-500	(2) 2/0-500	(2) 2/0-500	(2) 2/0-500
	230	4-500	4-500	1-250	1-250	(2) 2/0-500	(2) 2/0-500	(2) 2/0-500	(2) 2/0-500
	380	14-2/0	14-2/0	3/0-350	3/0-350	3/0-350	3/0-350	3/0-350	3/0-350
	460	14-2/0	14-2/0	3/0-350	3/0-350	3/0-350	3/0-350	3/0-350	3/0-350
	575	14-2/0	14-2/0	3/0-350	3/0-350	4-4/0	4-4/0	4-4/0	4-4/0
150	200	4-500	4-500	(2) 2/0-500	(2) 2/0-500	(2) 2/0-500	(2) 2/0-500	(2) 2/0-500	(2) 2/0-500
	230	4-500	4-500	1-250	(2) 2/0-500	(2) 2/0-500	(2) 2/0-500	(2) 2/0-500	(2) 2/0-500
	380	14-2/0	4-500	3/0-350	3/0-350	3/0-350	3/0-350	3/0-350	3/0-350
	460	14-2/0	14-2/0	3/0-350	3/0-350	3/0-350	3/0-350	3/0-350	3/0-350
	575	14-2/0	14-2/0	3/0-350	3/0-350	4-4/0	4-4/0	4-4/0	4-4/0
160	200	4-500	4-500	(2) 2/0-500	(2) 2/0-500	(2) 2/0-500	(2) 2/0-500	(2) 2/0-500	(2) 2/0-500
	230	4-500	4-500	(2) 2/0-500	(2) 2/0-500	(2) 2/0-500	(2) 2/0-500	(2) 2/0-500	(2) 2/0-500
	380	4-500	4-500	3/0-350	3/0-350	3/0-350	3/0-350	3/0-350	3/0-350
	460	14-2/0	14-2/0	3/0-350	3/0-350	3/0-350	3/0-350	3/0-350	3/0-350
	575	14-2/0	14-2/0	3/0-350	3/0-350	4-4/0	4-4/0	4-4/0	4-4/0
180	200	4-500	(2) 4-500	(2) 2/0-500	(2) 2/0-500	(2) 2/0-500	(2) 2/0-500	(2) 2/0-500	(2) 2/0-500
	230	4-500	4-500	(2) 2/0-500	(2) 2/0-500	(2) 2/0-500	(2) 2/0-500	(2) 2/0-500	(2) 2/0-500
	380	4-500	4-500	3/0-350	1-250	3/0-350	(2) 1-250	3/0-350	(2) 2/0-500
	460	14-2/0	4-500	3/0-350	3/0-350	3/0-350	3/0-350	3/0-350	3/0-350
	575	14-2/0	14-2/0	3/0-350	3/0-350	4-4/0	3/0-350	4-4/0	3/0-350

Table 36. Customer wire selection — RTWD, 60Hz, dual point power, high efficiency, high condensing temperature (continued)

Unit Size	Voltage	Terminal Block		Disconnect		Circuit Breaker		Ckt Brkr - Hi Fault	
		Ckt 1	Ckt 2	Ckt 1	Ckt 2	Ckt 1	Ckt 2	Ckt 1	Ckt 2
200	200	(2) 4-500	(2) 4-500	(2) 2/0-500	(2) 2/0-500	(2) 2/0-500	(2) 2/0-500	(2) 2/0-500	(2) 2/0-500
	230	4-500	4-500	(2) 2/0-500	(2) 2/0-500	(2) 2/0-500	(2) 2/0-500	(2) 2/0-500	(2) 2/0-500
	380	4-500	4-500	1-250	1-250	(2) 1-250	(2) 1-250	(2) 2/0-500	(2) 2/0-500
	460	4-500	4-500	3/0-350	3/0-350	3/0-350	3/0-350	3/0-350	3/0-350
	575	14-2/0	14-2/0	3/0-350	3/0-350	3/0-350	3/0-350	3/0-350	3/0-350
220	200	(2) 4-500	(2) 4-500	(2) 2/0-500	(3) 3/0-500	(2) 2/0-500	(3) 3/0-500	(2) 2/0-500	(3) 3/0-500
	230	4-500	(2) 4-500	(2) 2/0-500	(2) 2/0-500	(2) 2/0-500	(2) 2/0-500	(2) 2/0-500	(2) 2/0-500
	380	4-500	4-500	1-250	1-250	(2) 1-250	(2) 2/0-500	(2) 2/0-500	(2) 2/0-500
	460	4-500	4-500	3/0-350	1-250	3/0-350	(2) 1-250	3/0-350	(2) 2/0-500
	575	14-2/0	4-500	3/0-350	3/0-350	3/0-350	3/0-350	3/0-350	3/0-350
250	200	(2) 4-500	(2) 4-500	(3) 3/0-500	(3) 3/0-500	(3) 3/0-500	(3) 3/0-500	(3) 3/0-500	(3) 3/0-500
	230	(2) 4-500	(2) 4-500	(2) 2/0-500	(2) 2/0-500	(2) 2/0-500	(2) 2/0-500	(2) 2/0-500	(2) 2/0-500
	380	4-500	4-500	1-250	1-250	(2) 2/0-500	(2) 2/0-500	(2) 2/0-500	(2) 2/0-500
	460	4-500	4-500	1-250	1-250	(2) 1-250	(2) 1-250	(2) 2/0-500	(2) 2/0-500
	575	4-500	4-500	3/0-350	3/0-350	3/0-350	3/0-350	3/0-350	3/0-350

Notes:

1. Optional non-fused disconnect and circuit breaker.
2. Copper wire only, based on nameplate minimum circuit ampacity (MCA).
3. High condensing temperature option refers to entering condenser water temperatures above 95°F (35°C).

Table 37. Customer wire selection — RTWD, 60Hz, dual point power, premium efficiency, high condensing temperature

Unit Size	Voltage	Terminal Block		Disconnect		Circuit Breaker		Ckt Brkr - Hi Fault	
		Ckt 1	Ckt 2	Ckt 1	Ckt 2	Ckt 1	Ckt 2	Ckt 1	Ckt 2
150	200	4-500	4-500	1-250	(2) 2/0-500	(2) 2/0-500	(2) 2/0-500	(2) 2/0-500	(2) 2/0-500
	230	4-500	4-500	1-250	(2) 2/0-500	(2) 2/0-500	(2) 2/0-500	(2) 2/0-500	(2) 2/0-500
	380	14-2/0	4-500	3/0-350	3/0-350	3/0-350	3/0-350	3/0-350	3/0-350
	460	14-2/0	14-2/0	3/0-350	3/0-350	4-4/0	3/0-350	4-4/0	3/0-350
	575	14-2/0	14-2/0	3/0-350	3/0-350	4-4/0	4-4/0	4-4/0	4-4/0
160	200	4-500	4-500	(2) 2/0-500	(2) 2/0-500	(2) 2/0-500	(2) 2/0-500	(2) 2/0-500	(2) 2/0-500
	230	4-500	4-500	(2) 2/0-500	(2) 2/0-500	(2) 2/0-500	(2) 2/0-500	(2) 2/0-500	(2) 2/0-500
	380	4-500	4-500	3/0-350	3/0-350	3/0-350	3/0-350	3/0-350	3/0-350
	460	14-2/0	14-2/0	3/0-350	3/0-350	3/0-350	3/0-350	3/0-350	3/0-350
	575	14-2/0	14-2/0	3/0-350	3/0-350	4-4/0	4-4/0	4-4/0	4-4/0
180	200	4-500	4-500	(2) 2/0-500	(2) 2/0-500	(2) 2/0-500	(2) 2/0-500	(2) 2/0-500	(2) 2/0-500
	230	4-500	4-500	(2) 2/0-500	(2) 2/0-500	(2) 2/0-500	(2) 2/0-500	(2) 2/0-500	(2) 2/0-500
	380	4-500	4-500	3/0-350	1-250	3/0-350	(2) 1-250	3/0-350	(2) 2/0-500
	460	14-2/0	4-500	3/0-350	3/0-350	3/0-350	3/0-350	3/0-350	3/0-350
	575	14-2/0	14-2/0	3/0-350	3/0-350	4-4/0	3/0-350	4-4/0	3/0-350
200	200	4-500	4-500	(2) 2/0-500	(2) 2/0-500	(2) 2/0-500	(2) 2/0-500	(2) 2/0-500	(2) 2/0-500
	230	4-500	4-500	(2) 2/0-500	(2) 2/0-500	(2) 2/0-500	(2) 2/0-500	(2) 2/0-500	(2) 2/0-500
	380	4-500	4-500	1-250	1-250	(2) 1-250	(2) 1-250	(2) 2/0-500	(2) 2/0-500
	460	4-500	4-500	3/0-350	3/0-350	3/0-350	3/0-350	3/0-350	3/0-350
	575	14-2/0	14-2/0	3/0-350	3/0-350	3/0-350	3/0-350	3/0-350	3/0-350

Notes:

1. Optional non-fused disconnect and circuit breaker.
2. Copper wire only, based on nameplate minimum circuit ampacity (MCA).
3. High condensing temperature option refers to entering condenser water temperatures above 95°F (35°C).



Electrical Data

Table 38. Customer wire selection — RTUD, 60Hz, dual point power

Unit Size	Voltage	Terminal Block		Disconnect		Circuit Breaker		Ckt Brkr - Hi Fault	
		Ckt 1	Ckt 2	Ckt 1	Ckt 2	Ckt 1	Ckt 2	Ckt 1	Ckt 2
80	200	4-500	4-500	3/0-350	3/0-350	3/0-350	3/0-350	3/0-350	3/0-350
	230	4-500	14-2/0	3/0-350	3/0-350	3/0-350	3/0-350	3/0-350	3/0-350
	380	14-2/0	14-2/0	3/0-350	3/0-350	4-4/0	4-4/0	4-4/0	4-4/0
	460	14-2/0	14-2/0	3/0-350	3/0-350	8-3/0	8-3/0	8-3/0	8-3/0
	575	14-2/0	14-2/0	3/0-350	3/0-350	10-1/0	10-1/0	8-3/0	8-3/0
90	200	4-500	4-500	1-250	1-250	(2) 2/0-500	(2) 1-250	(2) 2/0-500	(2) 2/0-500
	230	4-500	4-500	3/0-350	3/0-350	3/0-350	3/0-350	3/0-350	3/0-350
	380	14-2/0	14-2/0	3/0-350	3/0-350	4-4/0	4-4/0	4-4/0	4-4/0
	460	14-2/0	14-2/0	3/0-350	3/0-350	4-4/0	4-4/0	4-4/0	4-4/0
	575	14-2/0	14-2/0	3/0-350	3/0-350	8-3/0	8-3/0	8-3/0	8-3/0
100	200	4-500	4-500	1-250	1-250	(2) 2/0-500	(2) 2/0-500	(2) 2/0-500	(2) 2/0-500
	230	4-500	4-500	3/0-350	1-250	3/0-350	(2) 2/0-500	3/0-350	(2) 2/0-500
	380	14-2/0	14-2/0	3/0-350	3/0-350	4-4/0	3/0-350	4-4/0	3/0-350
	460	14-2/0	14-2/0	3/0-350	3/0-350	4-4/0	4-4/0	4-4/0	4-4/0
	575	14-2/0	14-2/0	3/0-350	3/0-350	8-3/0	4-4/0	8-3/0	4-4/0
110	200	4-500	4-500	1-250	1-250	(2) 2/0-500	(2) 2/0-500	(2) 2/0-500	(2) 2/0-500
	230	4-500	4-500	1-250	1-250	(2) 2/0-500	(2) 2/0-500	(2) 2/0-500	(2) 2/0-500
	380	14-2/0	14-2/0	3/0-350	3/0-350	3/0-350	3/0-350	3/0-350	3/0-350
	460	14-2/0	14-2/0	3/0-350	3/0-350	4-4/0	4-4/0	4-4/0	4-4/0
	575	14-2/0	14-2/0	3/0-350	3/0-350	4-4/0	4-4/0	4-4/0	4-4/0
120	200	4-500	4-500	1-250	(2) 2/0-500	(2) 2/0-500	(2) 2/0-500	(2) 2/0-500	(2) 2/0-500
	230	4-500	4-500	1-250	(2) 2/0-500	(2) 2/0-500	(2) 2/0-500	(2) 2/0-500	(2) 2/0-500
	380	14-2/0	4-500	3/0-350	3/0-350	3/0-350	3/0-350	3/0-350	3/0-350
	460	14-2/0	14-2/0	3/0-350	3/0-350	4-4/0	3/0-350	4-4/0	3/0-350
	575	14-2/0	14-2/0	3/0-350	3/0-350	4-4/0	4-4/0	4-4/0	4-4/0
130	200	4-500	4-500	(2) 2/0-500	(2) 2/0-500	(2) 2/0-500	(2) 2/0-500	(2) 2/0-500	(2) 2/0-500
	230	4-500	4-500	(2) 2/0-500	(2) 2/0-500	(2) 2/0-500	(2) 2/0-500	(2) 2/0-500	(2) 2/0-500
	380	4-500	4-500	3/0-350	3/0-350	3/0-350	3/0-350	3/0-350	3/0-350
	460	14-2/0	14-2/0	3/0-350	3/0-350	3/0-350	3/0-350	3/0-350	3/0-350
	575	14-2/0	14-2/0	3/0-350	3/0-350	4-4/0	4-4/0	4-4/0	4-4/0
150	200	4-500	4-500	(2) 2/0-500	(2) 2/0-500	(2) 2/0-500	(2) 2/0-500	(2) 2/0-500	(2) 2/0-500
	230	4-500	4-500	(2) 2/0-500	(2) 2/0-500	(2) 2/0-500	(2) 2/0-500	(2) 2/0-500	(2) 2/0-500
	380	4-500	4-500	3/0-350	1-250	3/0-350	(2) 1-250	3/0-350	(2) 2/0-500
	460	14-2/0	4-500	3/0-350	3/0-350	3/0-350	3/0-350	3/0-350	3/0-350
	575	14-2/0	14-2/0	3/0-350	3/0-350	4-4/0	3/0-350	4-4/0	3/0-350
160	200	4-500	4-500	(2) 2/0-500	(2) 2/0-500	(2) 2/0-500	(2) 2/0-500	(2) 2/0-500	(2) 2/0-500
	230	4-500	4-500	(2) 2/0-500	(2) 2/0-500	(2) 2/0-500	(2) 2/0-500	(2) 2/0-500	(2) 2/0-500
	380	4-500	4-500	1-250	1-250	(2) 1-250	(2) 1-250	(2) 2/0-500	(2) 2/0-500
	460	4-500	4-500	3/0-350	3/0-350	3/0-350	3/0-350	3/0-350	3/0-350
	575	14-2/0	14-2/0	3/0-350	3/0-350	3/0-350	3/0-350	3/0-350	3/0-350
180	200	4-500	(2) 4-500	(2) 2/0-500	(3) 3/0-500	(2) 2/0-500	(3) 3/0-500	(2) 2/0-500	(3) 3/0-500
	230	4-500	4-500	(2) 2/0-500	(2) 2/0-500	(2) 2/0-500	(2) 2/0-500	(2) 2/0-500	(2) 2/0-500
	380	4-500	4-500	1-250	1-250	(2) 1-250	(2) 2/0-500	(2) 2/0-500	(2) 2/0-500
	460	4-500	4-500	3/0-350	3/0-350	3/0-350	3/0-350	3/0-350	3/0-350
	575	14-2/0	14-2/0	3/0-350	3/0-350	3/0-350	3/0-350	3/0-350	3/0-350

Table 38. Customer wire selection — RTUD, 60Hz, dual point power (continued)

Unit Size	Voltage	Terminal Block		Disconnect		Circuit Breaker		Ckt Brkr - Hi Fault	
		Ckt 1	Ckt 2	Ckt 1	Ckt 2	Ckt 1	Ckt 2	Ckt 1	Ckt 2
200	200	(2) 4-500	(2) 4-500	(3) 3/0-500	(3) 3/0-500	(3) 3/0-500	(3) 3/0-500	(3) 3/0-500	(3) 3/0-500
	230	(2) 4-500	4-500	(2) 2/0-500	(2) 2/0-500	(2) 2/0-500	(2) 2/0-500	(2) 2/0-500	(2) 2/0-500
	380	4-500	4-500	1-250	1-250	(2) 2/0-500	(2) 2/0-500	(2) 2/0-500	(2) 2/0-500
	460	4-500	4-500	3/0-350	3/0-350	3/0-350	3/0-350	3/0-350	3/0-350
	575	14-2/0	14-2/0	3/0-350	3/0-350	3/0-350	3/0-350	3/0-350	3/0-350
220	200	(2) 4-500	(2) 4-500	(3) 3/0-500	(3) 3/0-500	(3) 3/0-500	(3) 3/0-500	(3) 3/0-500	(3) 3/0-500
	230	(2) 4-500	(2) 4-500	(2) 2/0-500	(3) 3/0-500	(2) 2/0-500	(3) 3/0-500	(2) 2/0-500	(3) 3/0-500
	380	4-500	4-500	1-250	(2) 2/0-500	(2) 2/0-500	(2) 2/0-500	(2) 2/0-500	(2) 2/0-500
	460	4-500	4-500	3/0-350	1-250	3/0-350	(2) 2/0-500	3/0-350	(2) 2/0-500
	575	14-2/0	4-500	3/0-350	3/0-350	3/0-350	3/0-350	3/0-350	3/0-350
250	200	(2) 4-500	(2) 4-500	(3) 3/0-500	(3) 3/0-500	(3) 3/0-500	(3) 3/0-500	(3) 3/0-500	(3) 3/0-500
	230	(2) 4-500	(2) 4-500	(3) 3/0-500	(3) 3/0-500	(3) 3/0-500	(3) 3/0-500	(3) 3/0-500	(3) 3/0-500
	380	4-500	4-500	(2) 2/0-500	(2) 2/0-500	(2) 2/0-500	(2) 2/0-500	(2) 2/0-500	(2) 2/0-500
	460	4-500	4-500	1-250	1-250	(2) 2/0-500	(2) 2/0-500	(2) 2/0-500	(2) 2/0-500
	575	4-500	4-500	3/0-350	3/0-350	3/0-350	3/0-350	3/0-350	3/0-350

Notes:

1. Optional non-fused disconnect and circuit breaker.
2. Copper wire only, based on nameplate minimum circuit ampacity (MCA).

Electrical Connection

Figure 1. RTWD/RTUD - field wiring diagram

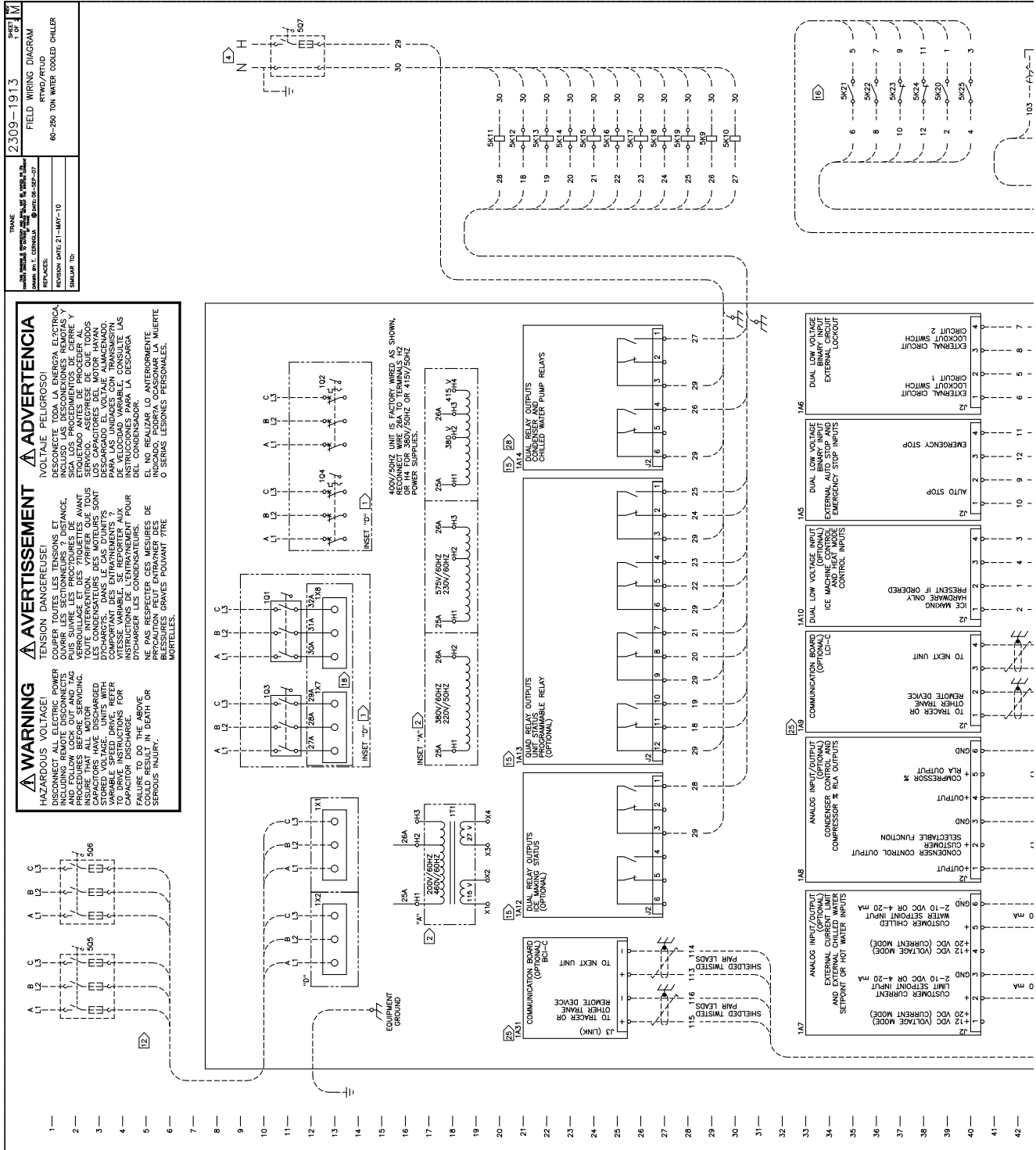

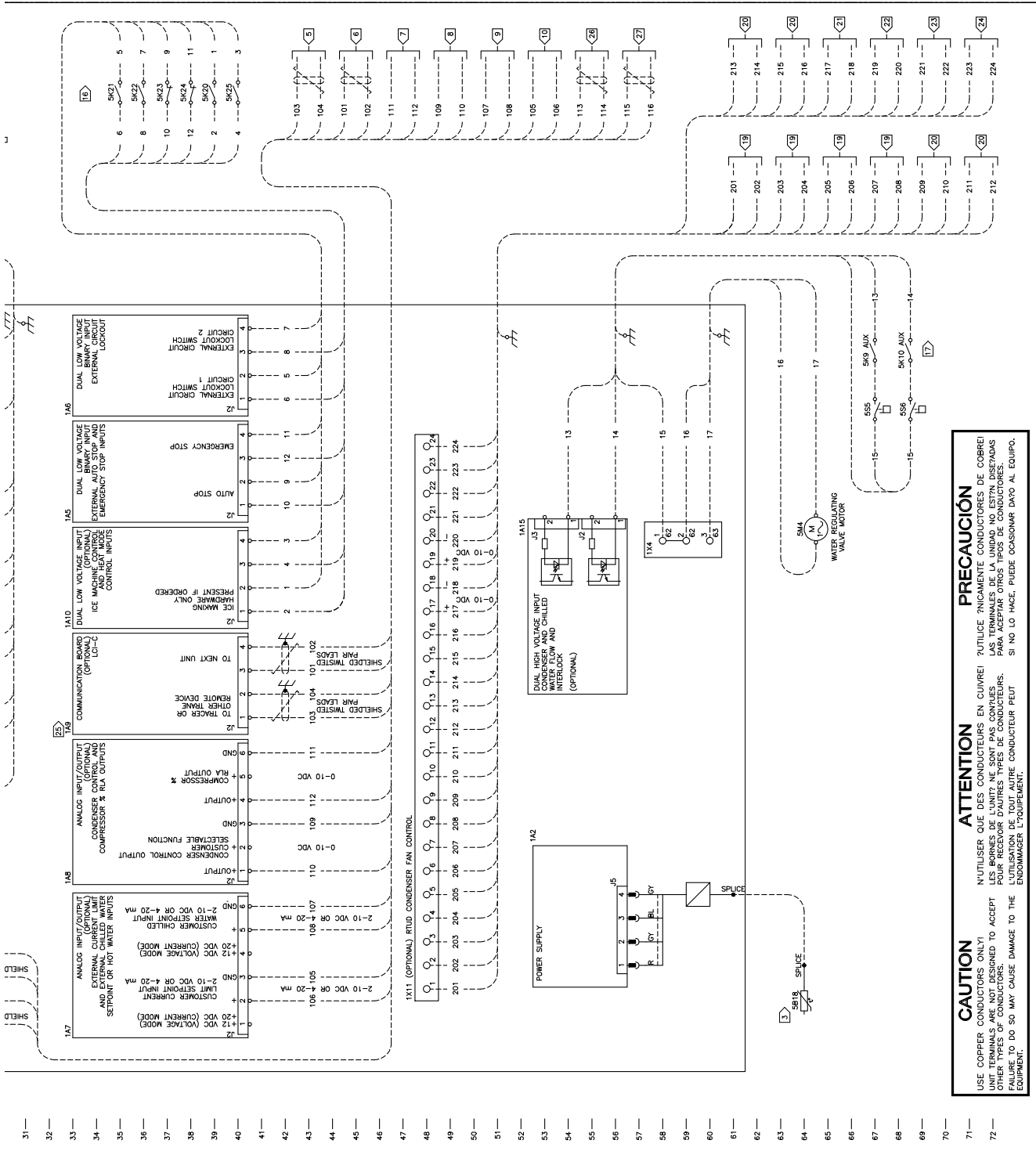

CAUTION
 USE COPPER CONDUCTORS ONLY.
 UNIT TERMINALS ARE NOT DESIGNED TO ACCEPT OTHER TYPES OF CONDUCTORS.
 FAILURE TO DO SO MAY CAUSE DAMAGE TO THE EQUIPMENT.

ATTENTION
 N'UTILISER QUE DES CONDUCTEURS EN CUIVRE.
 LES BORNES DE L'UNITÉ NE SONT PAS CONÇUES POUR RECEVOIR D'AUTRES TYPES DE CONDUCTEURS.
 L'UTILISATION DE TOUT AUTRE CONDUCTEUR PEUT ENDOMMAGER L'ÉQUIPEMENT.

PRECAUCIÓN
 UTILICE ÚNICAMENTE CONDUCTORES DE COBRE.
 LAS TERMINALES DE LA UNIDAD NO ESTÁN DISEÑADAS PARA ACEPTAR OTROS TIPOS DE CONDUCTORES.
 SI NO LO HACE, PUEDE OCASIONAR DAÑO AL EQUIPO.



Electrical Connection

Table 39. RTWD/RTUD - field wiring diagram notes

#	Description
1	Single source power is provided as standard on these products, dual source power is optional. Field connections for single source power are made to 1X1, 1Q1, or 1Q2. When dual source power is selected the field connections for circuit #2 are made to 1X2, 1Q3, or 1Q4.
2	For voltages 200 V/60 Hz, 220V/50Hz, 380 V/60 Hz, 460 V/60 Hz, wire 26A shall be connected to H2. For voltages 230 V/60 Hz and 575 V/60 Hz, wire 26A shall be connected to H3. 400 V/50 Hz unit is factory wired with 26A connected to H3 - reconnect wire 26A to H2 for 380V/50Hz, or H4 for 415V/50Hz. H4 is only available with 400V/50Hz panels.
3	Factory installed outdoor air temperature sensor lead length to be spliced and extended by customer. 18 AWG twisted pair recommended.
4	Customer supplied power 115/60/1 to power relays. Max fuse size is 15 amps. Ground all customer supplied power supplied as required by applicable codes. Green ground screws are provided in unit control panel.
5	Wired to next unit. 22 AWG shielded communication wire equivalent to helix LF22P0014216 recommended. The sum total of all interconnected cable segments not to exceed 4500 feet. Connection topology should be daisy chain. Refer to building automation system (BAS) communication installation literature for end of line termination resistor requirements.
6	Wired to Tracer or other Trane remote device. 22 AWG shielded communication wire equivalent to helix LF22P0014216 recommended. The sum total of all interconnected cable segments not to exceed 4500 feet. Connection topology should be daisy chain. Refer to building automation system (BAS) communication installation literature for end of line termination resistor requirements
7	Wired to compressor % RLA.
8	Wired to condenser control customer selectable function.
9	Wired to customer chilled water setpoint 2-10 V or 4-20 mA.
10	Wired to customer current limit setpoint 2-10 V or 4-20 mA.
11	Refer to electrical schematic for specific electrical connection information and notes pertaining to wiring installation.
12	All unit power wiring must be 600-V copper conductors only and have a minimum temperature insulation rating of 75°C. Refer to unit nameplate for minimum circuit ampacity and maximum overcurrent protection device. Provide an equipment ground in accordance with applicable electric codes.
13	All field wiring must be in accordance with national electric code and local requirements.
14	All customer control circuit wiring must be copper conductors only and have a minimum insulation rating of 300 volts. Except as noted, all customer wiring connection are made to circuit board mounted box lugs with a wire range of 14 to 18 AWG.
15	Unit provided dry contacts for the condenser/chilled water pump control. Relays are rated for 7.2 amps resistive, 2.88 amps pilot duty, or 1/3 HP, 7.2 FLA at 120 volts 60Hz. Contacts are rated for 5 A general purpose duty 240-V.
16	Customer supplied contacts for all low voltage connections must be compatible with dry circuit 24 VDC for a 12 mA resistive load. Silver or gold plated contacts recommended.
17	Flow switch and interlock contacts must be acceptable for use in a 120-V, 1-mA circuit or a 220-V, 2-mA circuit.
18	Only present on "ED" frame molded case switches. 1X7, 1X8, 27A, 28A, 29A, 30A, 31A, and 32A are not present with all other molded case switches.
19	Wires are connected to normally open dry contacts for circuit 1 condenser fan. Control relays are rated for 7.2 amps resistive, 2.88 amps pilot duty, or 1/3 HP. Contacts are rated for 7.2 FLA at 120-V or 5 amps general purpose duty at 240-V. Wires 201 and 202 enable fan group 1. Wires 203 and 204 enable fan group 2. Wires 205 and 206 enable group 3. Wires 207 and 208 enable fan group 4. Fan groups 1 and 2 may be combined for two speed fan control. Wires 201 and 202 enable part speed. Wires 203 and 204 enable full speed. When properly configured, RTUD controls will never enable both signals simultaneously and will provide a short delay between signals. Trane recommends the user of mechanical and electronic interlocks to prevent equipment damage in the event of contact failure or misconfiguration.
20	Wires are connected to normally open dry contacts for circuit 1 condenser fan. Control relays are rated for 7.2 amps resistive, 2.88 amps pilot duty, or 1/3 HP. Contacts are rated for 7.2 FLA at 120-V or 5 amps general purpose duty at 240-V. Wires 209 and 210 enable fan group 1. Wires 211 and 212 enable fan group 2. Wires 213 and 214 enable group 3. Wires 215 and 216 enable fan group 4. Fan groups 1 and 2 may be combined for two speed fan control. Wires 209 and 210 enable part speed. Wires 211 and 212 enable full speed. When properly configured, RTUD controls will never enable both signals simultaneously and will provide a short delay between signals. Trane recommends the user of mechanical and electronic interlocks to prevent equipment damage in the event of contact failure or misconfiguration.
21	Wires are connected to 0-10 VDC signal at 22 mA maximum for circuit 1, group 1, condenser fan speed control.
22	Wires are connected to 0-10 VDC signal at 22 mA maximum for circuit 2, group 1, condenser fan speed control.
23	Wires are connected to circuit 1, group 1, condenser fan fault feedback. Connection must be compatible with dry circuit 24 VDC for a 12-mA resistive load. Silver or gold plated contacts recommended.
24	Wires are connected to circuit 2, group 1, condenser fan fault feedback. Connection must be compatible with dry circuit 24 VDC for a 12-mA resistive load. Silver or gold plated contacts recommended.

Table 39. RTWD/RTUD - field wiring diagram notes

#	Description
25	1A31 (BACnet) and 1A9 (LonTalk) may not be installed on the same unit.
26	Wired to next unit. 18-AWG, 24-pF/ft, shielded communication wire recommended. The sum total of all interconnected cable segments not to exceed 4000 feet. Connection topology should be daisy chain. Limit link to 60 Trane devices or 32 devices of Trane and non-Trane manufacture.
27	Wired to Tracer or other Trane remote device. 18-AWG, 24-pF/ft, shielded communication wire recommended. The sum total of all interconnected cable segments not to exceed 4000 feet. Connection topology should be daisy chain. Limit link to 60 Trane devices or 32 devices of Trane and non-Trane manufacture.
28q	All RTUD units (systems with a remote condenser) require chilled water pumps be control by the Trane CH530 to avoid catastrophic damage to the evaporator due to freezing. It is strongly recommended that chilled water pump control also be used on RTWD to provide proper unit operation.

RTWD/RTUD - replaceable fuse table

Volts	Hertz	Designation	Class	Quantity	Size (A)
200	60	1F13, 14	CC	2	10
		1F18, 19, 20, 21	CC	4	3
		1F16, 17	CC	2	6
		1F15	CC	1	10
230	60	1F13, 14	CC	2	8
		1F18, 19, 20, 21	CC	4	3
		1F16, 17	CC	2	6
		1F15	CC	1	10
380	60	1F13, 14	CC	2	5
		1F18, 19, 20, 21	CC	4	3
		1F16, 17	CC	2	6
		1F15	CC	1	10
460	60	1F13, 14	CC	2	5
		1F18, 19, 20, 21	CC	4	3
		1F16, 17	CC	2	6
		1F15	CC	1	10
575	60	1F13, 14	CC	2	4
		1F18, 19, 20, 21	CC	4	3
		1F16, 17	CC	2	6
		1F15	CC	1	10

Table 40. RTWD/RTUD connection diagram notes

#	Description		Additional Information
1	Line voltage entrance (see unit nameplate)	location	
2	Power section	location	
3	Controls section	location	
4	Customer control power high voltage entrance	location	
5	Customer control power low voltage entrance	location	
6	Condenser and chilled water flow inputs.	optional	1A15, (5K10 and 5K9)
7	Condenser and chilled water pump relay outputs. Separate 115/60/1 customer power is required.	optional	1A14, (5K10 and 5K9)
8	Unit status programmable relay outputs. Separate 115/60/1 customer power is required.	optional	1A13, (5K12–5K19)
9	Ice making status relay output. Separate 115/60/1 customer power is required.	optional	1A12, (5K11)
10	External auto stop and emergency stop inputs.	standard	1A5, (5K23 and 5K24)
11	External circuit lockout inputs circuit 1 and circuit 2.	standard	1A6, (5K21 and 5K22)
12	External current-limit and chilled water setpoint or hot water inputs.	optional	1A7, (4-20 mA or 2-10 V)
13	Condenser control and compressor % RLA input.	optional	1A8, (4-20 mA or 0-10 V)
14	Tracer Communications	optional	1A9
15	Ice machine control and heat mode control.	optional	1A10, (5K20 and 5K25)
16	Circuit 1 disconnect	optional	1A6
17	Circuit 2 disconnect	optional	1A6
18	Wye-delta closed transition starter or across-the-line starter circuit 1A	location	
19	Wye-delta closed transition starter or across-the-line starter circuit 2A	location	
20	Refer to RTWD/RTUD electrical schematic for specific electrical connection information and notes pertaining to wiring installation.		
21	RTWD condenser control	optional	1A8
22	Outdoor air temperature sensor	optional (RTWD)	

Electrical Connection

Figure 3. RTWD/RTUD layout diagram

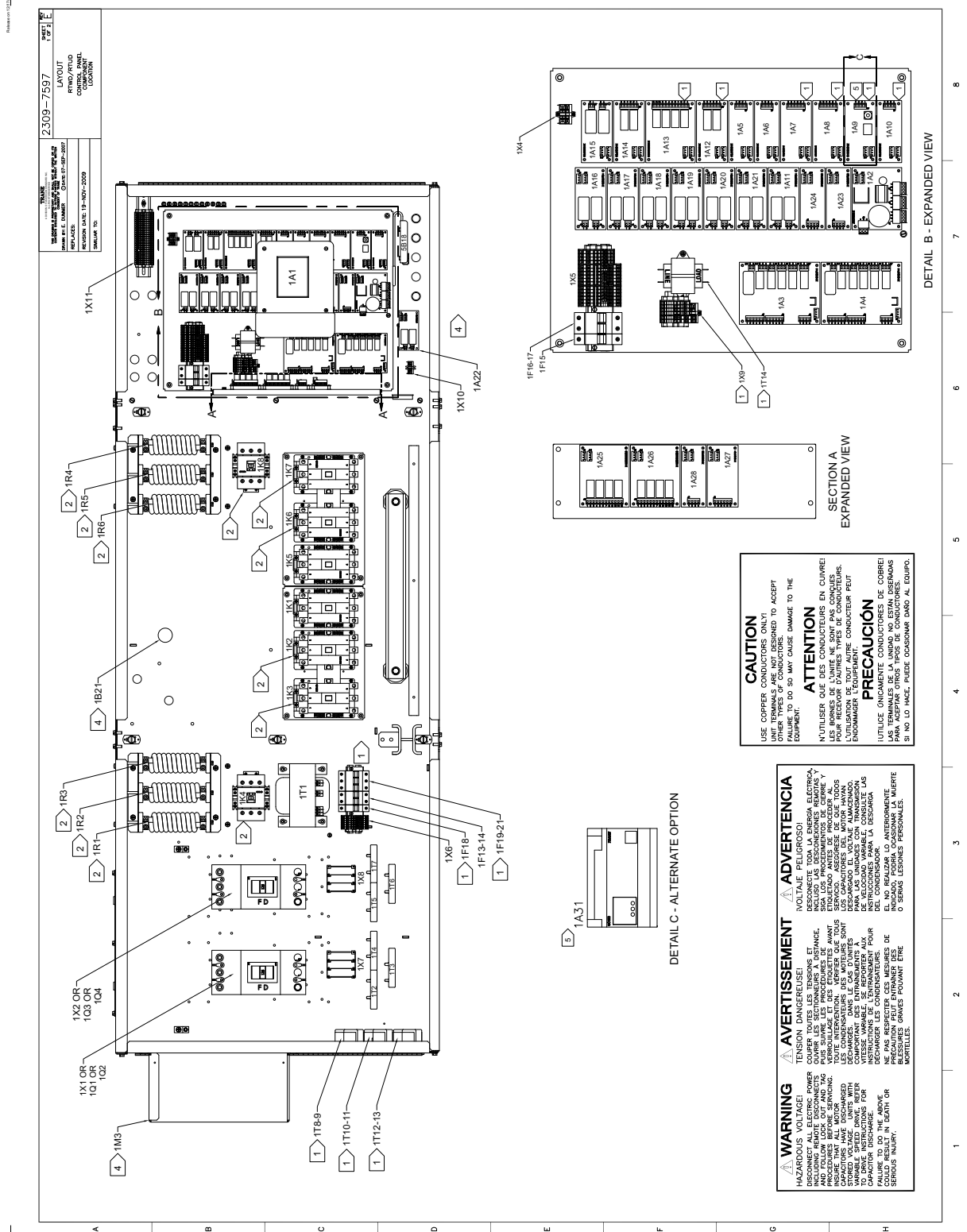

Table 41. RTWD/RTUD layout notes

1A1	Dyna View main processor interface	** 1K2	Contactor, compressor 1A run.
1A2	Power supply module.	** 1K3	Contactor, compressor 1A short.
1A3	Starter module, compressor 1A.	** 1K4	Contactor, compressor 1A transition.
1A4	Starter module, compressor 2A.	1K5	Contactor, compressor 2A start.
1A5	Dual low voltage input, external auto stop and emergency stop inputs.	** 1K6	Contactor, compressor 2A run.
1A6	Dual low voltage input, external circuit lockout, refrigerant circuit 1 and 2.	** 1K7	Contactor, compressor 2A short.
* 1A7	Analog input/output, external current limit and external chilled water or hot water setpoint inputs.	** 1K8	Contactor, compressor 2A transition.
* 1A8	Analog input/output, condenser control and compressor % RLA output.	* 1Q1	Disconnect switch, power distribution.
* 1A9	CH530 COMM5 interface, LCI-C communications (Echelon).	* 1Q2	Circuit breaker, power distribution.
* 1A10	Dual low voltage input, ice machine control and heat mode control.	* 1Q3	Disconnect switch, power distribution.
* 1A11	Dual high voltage input, motor thermostats compressor 2A and 1A.	* 1Q4	Circuit breaker, power distribution.
* 1A12	Dual relay output, ice making status.	** 1R1	Resistor, transition, compressor 1A, line A.
* 1A13	Quad relay outputs, unit status programmable relays.	** 1R2	Resistor, transition, compressor 1A, line B.
1A14	Dual relay output, condenser and chilled water pump relays.	** 1R3	Resistor, transition, compressor 1A, line C.
1A15	Dual high voltage input, condenser and chilled water flow and interlock.	** 1R4	Resistor, transition, compressor 2A, line A.
1A16	Dual triac output, modulating unload and load compressor 2A.	** 1R5	Resistor, transition, compressor 2A, line B.
1A17	Dual triac output, step load control compressor 2A and 1A.	** 1R6	Resistor, transition, compressor 2A, line C.
1A18	Dual triac output, modulating unload and load compressor 1A.	1T1	Transformer, control power.
1A19	Dual high voltage input, high pressure cutout compressor 2A and 1A.	1T2	Transformer, current, compressor 1A, line A.
1A20	Dual triac output, oil return gas pump drain and fill, circuit 2.	1T3	Transformer, current, compressor 1A, line B.
1A21	Dual triac output, oil return gas pump drain and fill, circuit 1.	1T4	Transformer, current, compressor 1A, line C.
*** 1A22	Dual high voltage input, panel ventilation.	1T5	Transformer, current, compressor 2A, line A.
1A23	Dual low voltage input, oil loss level.	1T6	Transformer, current, compressor 2A, line B.
* 1A24	Dual low voltage input, water flow sensor.	1T7	Transformer, current, compressor 2A, line C.
* 1A25	Quad relay outputs, circuit 1 fan control.	* 1T8	Transformer, potential, under/over voltage - power meter, line A to B.
* 1A26	Quad relay outputs, circuit 2 fan control.	* 1T9	Transformer, potential, power meter, line B to C.
* 1A27	Analog input/output, fan speed control.	* 1T10	Transformer, potential, power meter, line A to C.
* 1A28	Dual low voltage input, fault feedback.	* 1T11	Transformer, potential, power meter, line A to B.
* 1A31	UC400, Tracer, BCI-C communications.	* 1T12	Transformer, potential, power meter, line B to C.
*** 1B21	Thermostat, panel ventilation	* 1T13	Transformer, potential, power meter, line A to C.
*** 1M3	Motor, ventilation fan.	* 1X1	Power distribution block.
1F13	Fuse, potential transformer primary, compressor 1A, line A, under/over voltage - power meter.	* 1X2	Power distribution block.
1F14	Fuse, potential transformer primary, compressor 1A, line B, under/over voltage - power meter.	1X4	Terminal strip, customer control wiring.
1F15	Fuse, control power transformer secondary, 115 V.	1X5	Terminal strip, factory control wiring.
1F16	Fuse, control power transformer secondary, 27 V.	* 1X6	Terminal strip, factory power meter wiring.
1F17	Fuse, control power transformer secondary, 27 V.	* 1X7	Power distribution block.
* 1F18	Fuse, potential transformer primary, compressor 1A, line C, power meter.	* 1X8	Power distribution block.
* 1F19	Fuse, potential transformer primary, compressor 2A, line A, power meter.	1X9	Terminal strip, water flow sensor control wiring.
* 1F20	Fuse, potential transformer primary, compressor 2A, line B, power meter.	*** 1X10	Terminal strip, ventilation.
* 1F21	Fuse, potential transformer primary, compressor 2A, line C, power meter.	* 1X11	Terminal strip, fan control.
1K1	Contactor, compressor 1A start.	* 5B18	Temperature sensor, outdoor air temperature.

Notes: Refer to RTWD/RTUD electrical schematic for specific electrical connection information and notes pertaining to wiring installation. 1A31 may optionally be installed in place of 1A9.

* - Optional components; may not be present on all units. ** - Wye-delta components; may not be present on all units. *** - Only present when ventilation is required.

Dimensions

Dimensions — Units with Standard Condenser Waterbox

Figure 4. RTWD/RTUD 80 to 140 tons, 60 Hz

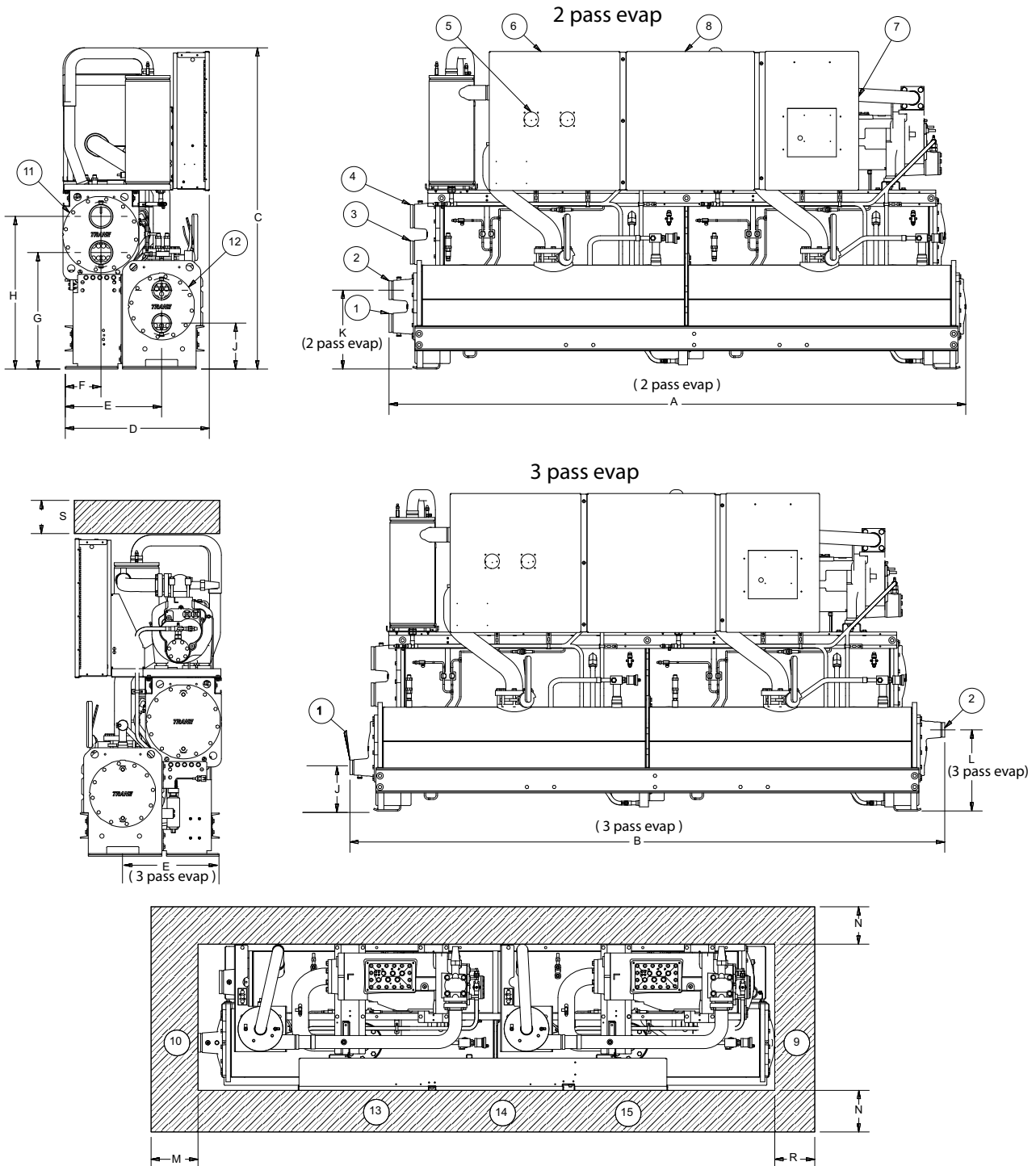

Table 42. RTWD/RTUD, 80 to 140 tons, 60 Hz – in (mm)

	Standard Efficiency			RTWD/RTUD - High Efficiency	
	80,90T	100,110T	120,130,140T	80,90T	100,110,120,130T
A (2 pass evap)	138.2 (3510)	138.2 (3510)	138.8 (3525)	126.4 (3210)	126.9 (3225)
B (3 pass evap)	142.6 (3621)	142.6 (3621)	142.6 (3621)	130.8 (3321)	130.7 (3320)
C	75.9 (1929)	76.9 (1955)	76.9 (1955)	76.1 (1933)	76.9 (1955)
D	34.3 (871)	34.3 (871)	34.8 (884)	35.1 (890)	35.1 (890)
E	23.6 (600)	23.6 (600)	23.6 (600)	23.6 (600)	23.6 (600)
F	9.1 (231)	9.1 (231)	9.1 (231)	9.1 (231)	9.1 (231)
G	27.9 (709)	27.9 (709)	27.9 (709)	27.9 (709)	27.9 (709)
H	36.6 (929)	36.6 (929)	36.6 (929)	36.6 (929)	36.6 (929)
J (2 pass evap)	11.0 (280)	11.0 (280)	10.6 (268)	10.8 (273)	11.8 (299)
J (3 pass evap)	10.4 (265)	10.4 (265)	10.1 (256)	10.2 (258)	11.3 (287)
K (2 pass evap)	18.9 (479)	18.9 (479)	19.2 (487)	18.6 (472)	20.4 (519)
L (3 pass evap)	19.5 (495)	19.5 (495)	19.5 (496)	19.2 (488)	19.2 (487)
M	36 (914)	36 (914)	36 (914)	36 (914)	36 (914)
N*	36 (914)*	36 (914)*	36 (914)*	36 (914)*	36 (914)*
R	127 (3226)	127 (3226)	127 (3226)	115 (2921)	115 (2921)
S	36 (914)	36 (914)	36 (914)	36 (914)	36 (914)

Reference

- 1** Evaporator Water Inlet
- 2** Evaporator Water Outlet
- 3** Condenser Water Inlet (RTWD only)
- 4** Condenser Water Outlet (RTWD only)
- 5** Power Disconnect
- 6** Power Wire
- 7** Control Wire
- 8** Control Panel
- 9** Condenser Return Waterbox End (RTWD only) - minimum clearance (for tube removal)
- 10** Condenser Supply Waterbox End (RTWD only) - minimum clearance (for maintenance)
- 11** Condenser (RTWD only)
- 12** Evaporator
- 13** Panel Power Section - door swing 31.3 inch (796.9 mm)
- 14** Panel Power Section - door swing 31.1 inch (790.1 mm)
- 15** Panel Control Section - door swing 22.4 inch (568.14 mm)
- *** 42 inch (1067 mm) clearance required to other ground parts, two units with panels facing each other or other live parts require a clearance of 48 inch (1220 mm)
- **** Sound attenuator may increase the footprint - submittal should be used.

Dimensions

Figure 5. RTWD/RTUD, 150 to 250 tons, 60 Hz

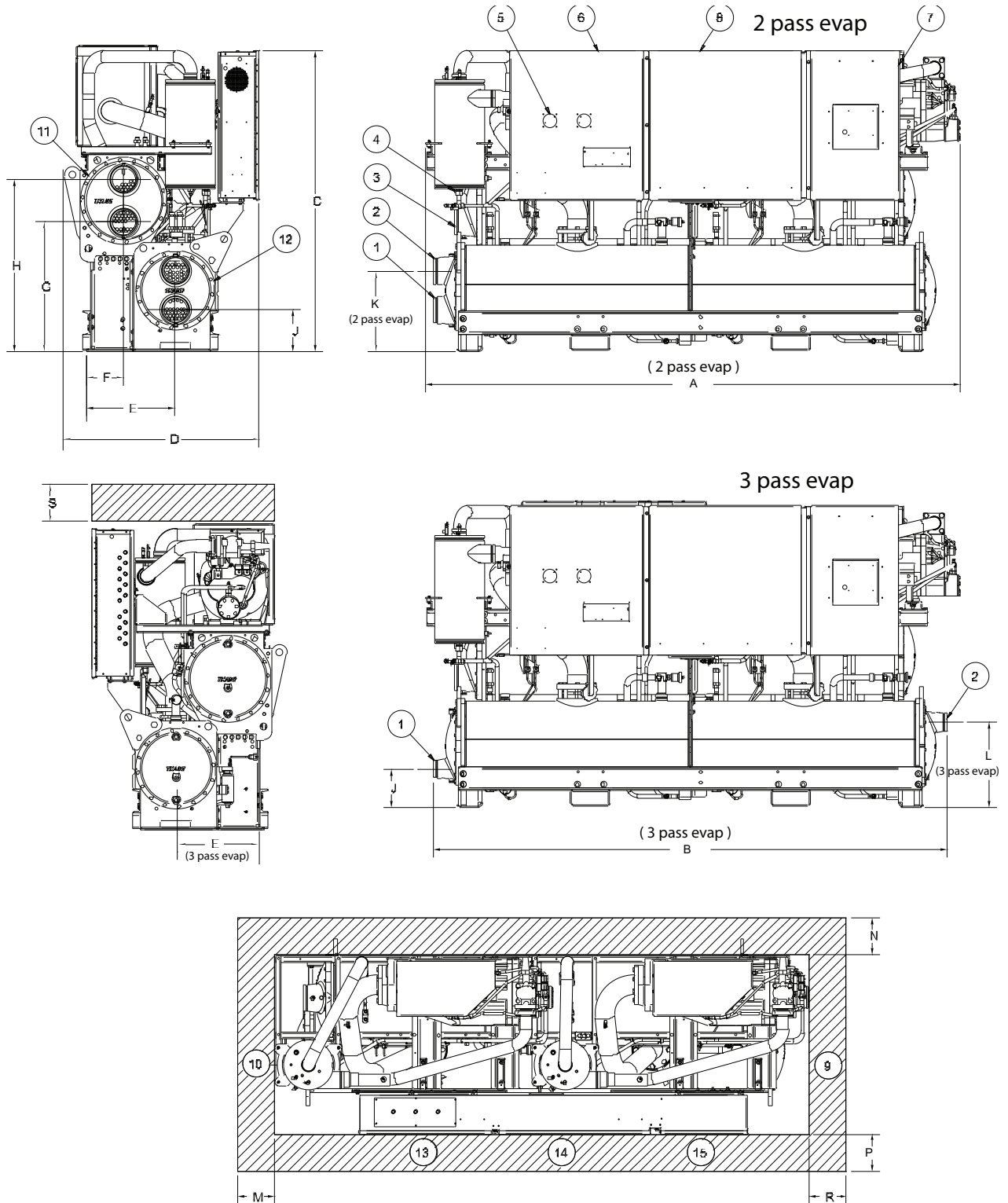

Table 43. RTWD/RTUD, 150 to 250 tons, 60 Hz – in (mm)

	RTWD			RTUD		
	High Efficiency		Prem Efficiency	High Efficiency		
	150-200T	220, 250T	150-200T	150T	160-200T	220,250Y
A (2 pass evap)	132.3 (3360)	136.1 (3456)	147.9 (3755)	126.9 (3225)	132.3 (3360)	132.3 (3360)
B (3 pass evap)	132.8 (3371)	136.1 (3456)	150.9 (3831)	130.8 (3321)	132.8 (3371)	132.9 (3376)
C	75.6 (1920)	76.9 (1955)	76.8 (1950)	76.9 (1955)	75.6 (1920)	76.7 (1949)
D	47.3 (1202)	47.8 (1213)	47.3 (1202)	37.9 (962)	47.4 (1203)	47.4 (1203)
E	24.6 (624)	24.8 (630)	24.6 (624)	23.5 (599)	24.5 (624)	24.6 (624)
F	11.1 (282)	11.2 (295)	11.1 (282)	-	-	-
G	32.7 (830)	33.1 (840)	33.8 (860)	-	-	-
H	42.4 (1078)	43.9 (1115)	43.6 (1108)	-	-	-
J (2 pass evap)	10.1 (256)	10.6 (270)	10.6 (270)	10.2/259	10.1 (256)	11.3 (263)
J (3 pass evap)	9.5 (241)	9.7 (247)	9.7 (247)	9.8/247	9.5 (241)	8.8 (223)
K (2 pass evap)	19.3 (490)	20.6 (524)	20.6 (524)	18.9/479	19.3 (490)	19.9 (483)
L (3 pass evap)	19.9 (505)	21.6 (549)	21.6 (549)	19.8/501	19.9 (505)	20.7 (526)
M	36.0 (914)	36.0 (914)	36.0 (914)	36.0 (914)	36.0 (914)	36.0 (914)
N	36.0 (914)	36.0 (914)	36.0 (914)	36.0 (914)	36.0 (914)	36.0 (914)
P*	40 (1016)*	40 (1016)*	40 (1016)*	40 (1016)*	40 (1016)*	40 (1016)*
R	114.8 (2916)	114.8 (2916)	134.5 (3416)	114.8 (2916)	114.8 (2916)	114.8 (2916)
S	36.0 (914)	36.0 (914)	36.0 (914)	36.0 (914)	36.0 (914)	36.0 (914)

Reference

- 1** Evaporator Water Inlet
- 2** Evaporator Water Outlet
- 3** Condenser Water Inlet (RTWD only)
- 4** Condenser Water Outlet (RTWD only)
- 5** Power Disconnect
- 6** Power Wire
- 7** Control Wire
- 8** Control Panel
- 9** Condenser Return Waterbox End (RTWD only) - minimum clearance (for tube removal)
- 10** Condenser Supply Waterbox End (RTWD only) - minimum clearance (for maintenance)
- 11** Condenser (RTWD only)
- 12** Evaporator
- 13** Panel Power Section - door swing 31.3 inch (796.9 mm)
- 14** Panel Power Section - door swing 31.1 inch (790.1 mm)
- 15** Panel Control Section - door swing 22.4 inch (568.14 mm)

Control panel clearance is 36 or 40 inch (914 or 1016 mm) depending on voltages, starter type, unit application and local code; 42 inch (1067 mm) clearance required to other grounded parts; two units with panels facing each other or other live parts require a clearance of 48 inch (1220 mm).

*

**

Sound attenuator may increase the footprint - submittal should be used.

Dimensions – Units with Marine Waterbox Option

Overall unit dimensions and condenser water connection dimensions are shown in [Table 44](#). All other dimensions are the same as units with a standard waterbox, as specified in “[Dimensions – Units with Standard Condenser Waterbox](#),” p. 72.

Figure 6. Dimensions – marine waterbox option^(a)

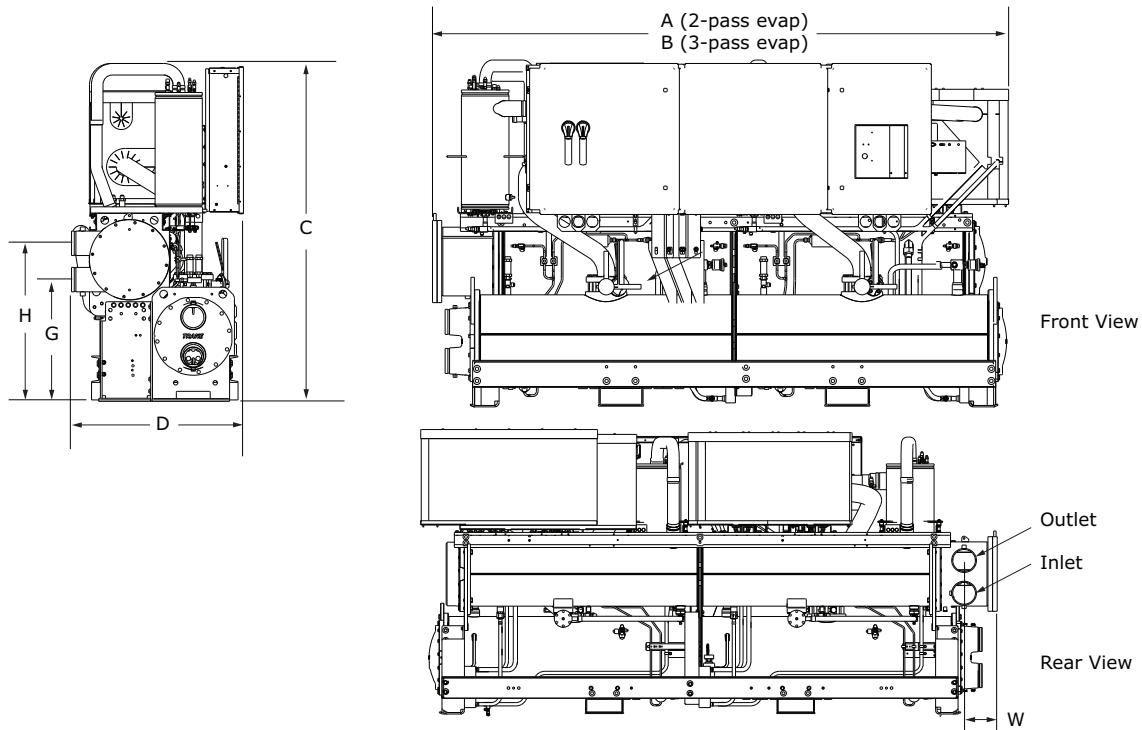

(a) All dimensions are to the outer point of the unit. Depending on configuration, outer point may vary from that shown.

Table 44. Dimensions – marine waterbox option

Size (tons)	Hz	Effic	A		B		D		C		G		H		W	
			in	mm	in	mm	in	mm	in	mm	in	mm	in	mm	in	mm
80, 90	60	High	129.0	3277.6	133.4	3388.5	41.4	1051.7	76.3	1937.5	27.7	704	36.0	914	6.9	176
80-110	60	Std	140.9	3577.8	145.2	3688.5	39.1	994.1	77.0	1954.8	27.7	704	36.0	914	6.9	176
100-130	60	High	130.3	3308.9	133.6	3392.5	41.4	1051.7	77.0	1954.8	27.7	704	36.0	914	6.9	176
120-140	60	Std	141.5	3593.0	145.2	3688.5	39.1	994.1	76.9	1953.7	27.7	704	36.0	914	6.9	176
150-200	60	High	139.9	3552.6	139.4	3541.1	50.0	1269.0	77.6	1970.5	32.2	819	41.3	1049	7.6	193.5
150-200	60	Prem	154.1	3915.1	154.9	3934	51.2	1300.6	78.9	2004.0	33.4	848.5	42.5	1078.5	7.6	193.5
220, 250	60	High	140.2	3559.9	140.2	3559.9	51.7	1313.5	79.1	2009.5	32.6	828	42.8	1088	8.0	203

RTWD and RTUD Unit Footprint

Figure 7. Unit footprint

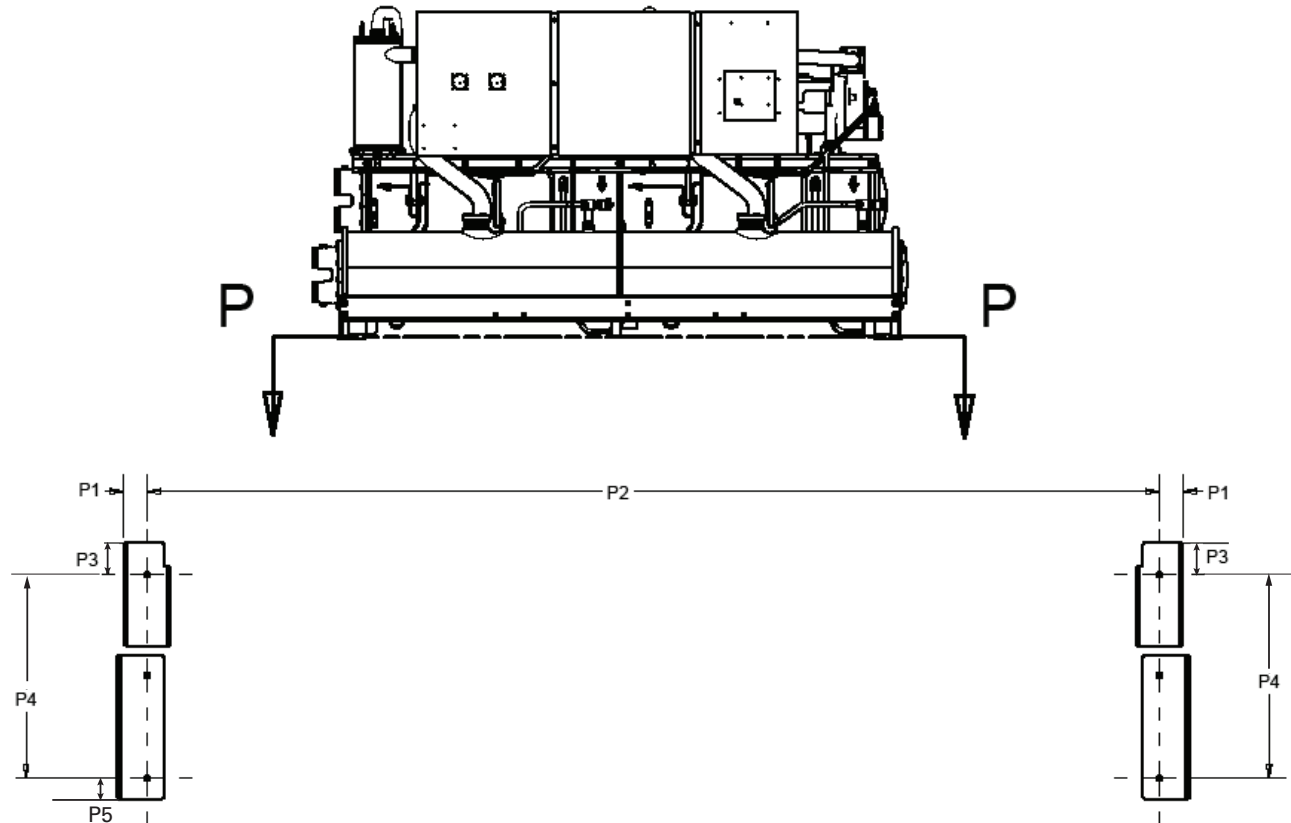

Table 45. RTWD/RTUD unit footprint

Dimension	Standard Efficiency		High Efficiency 80 - 130T (60Hz)		High Efficiency 150 - 250T (60Hz),		Premium Efficiency 150-200T (60Hz)	
	inch	mm	inch	mm	in	mm	inch	mm
P1	3.68	93.5	3.68	93.5	3.68	93.5	3.68	93.5
P2	123.78	3144	111.97	2844	111.97	2844	131.65	3344
P3	2.43	61.8	2.43	61.8	4.3	109.3	4.3	109.3
P4	24.93	633.2	24.9	633.2	24.9	633.2	24.9	633.2
P5	2.5	64	2.5	64	2.5	64	2.5	64

Note: Base hole diameters all 0.63 inch (16 mm).

Dimensions — Trane Air-Cooled Condenser

Figure 8. Air-cooled condenser —
80, 150 and 160 ton (condenser 1 and 2), 180 ton (condenser 1)

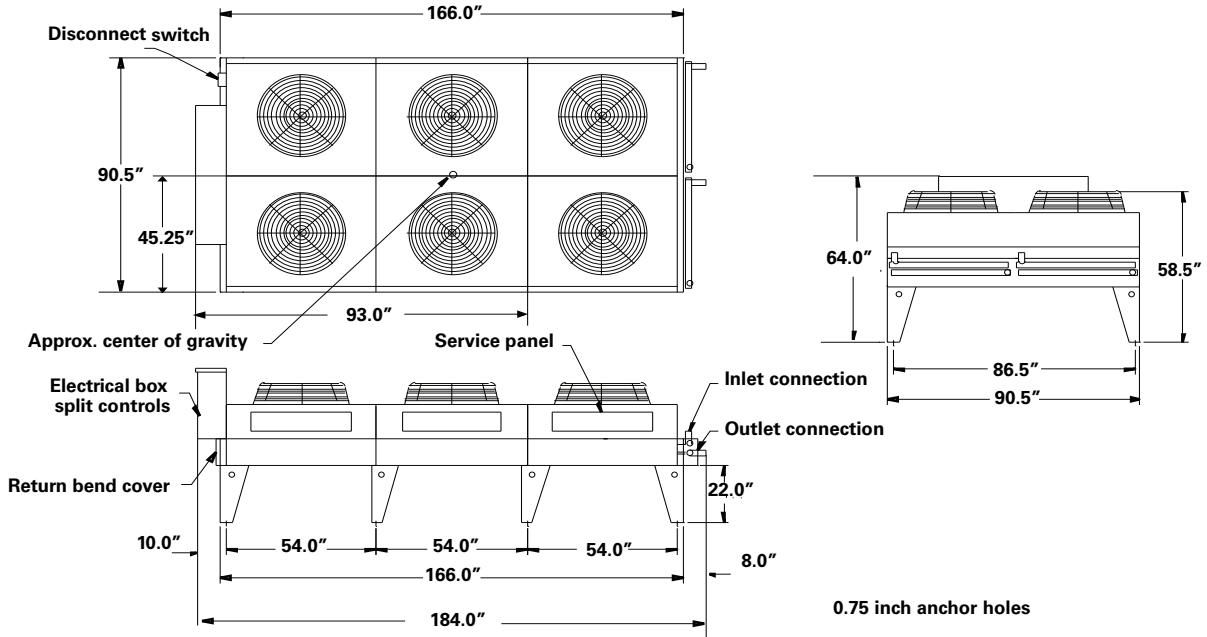

Figure 9. Air-cooled condenser —
90, 100, 110, 200, 220 and 250 ton (condenser 1 and 2), 180 ton (condenser 2)

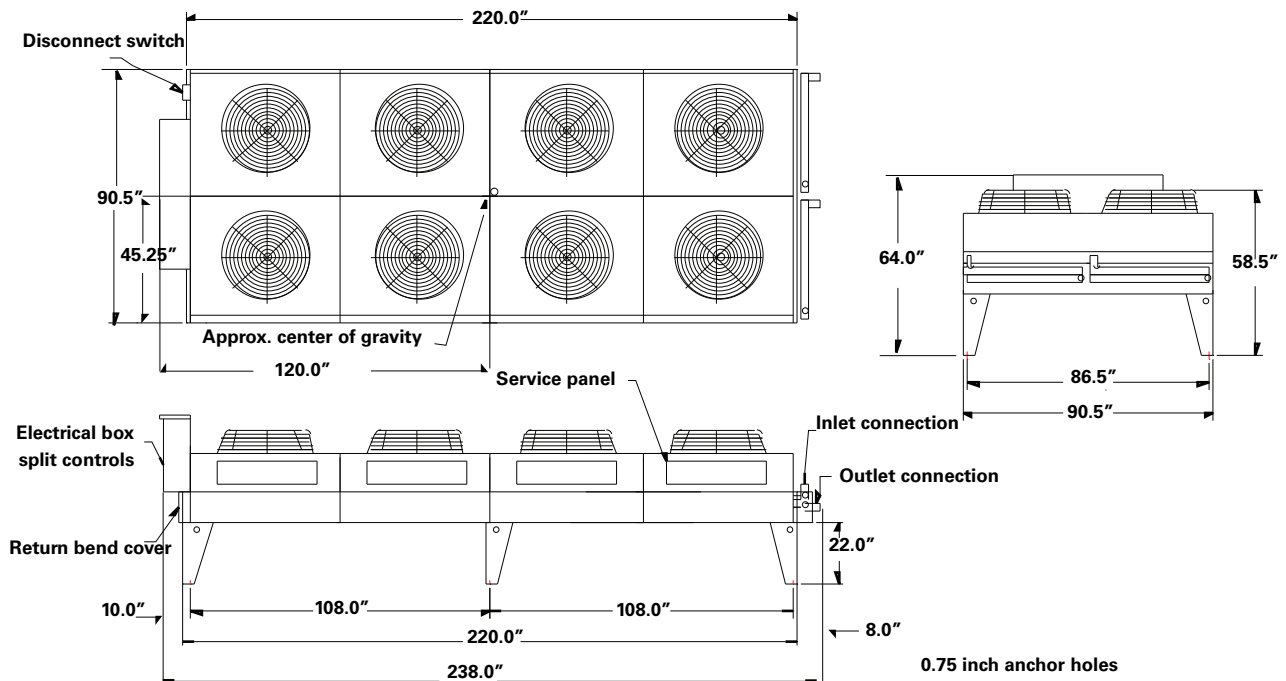
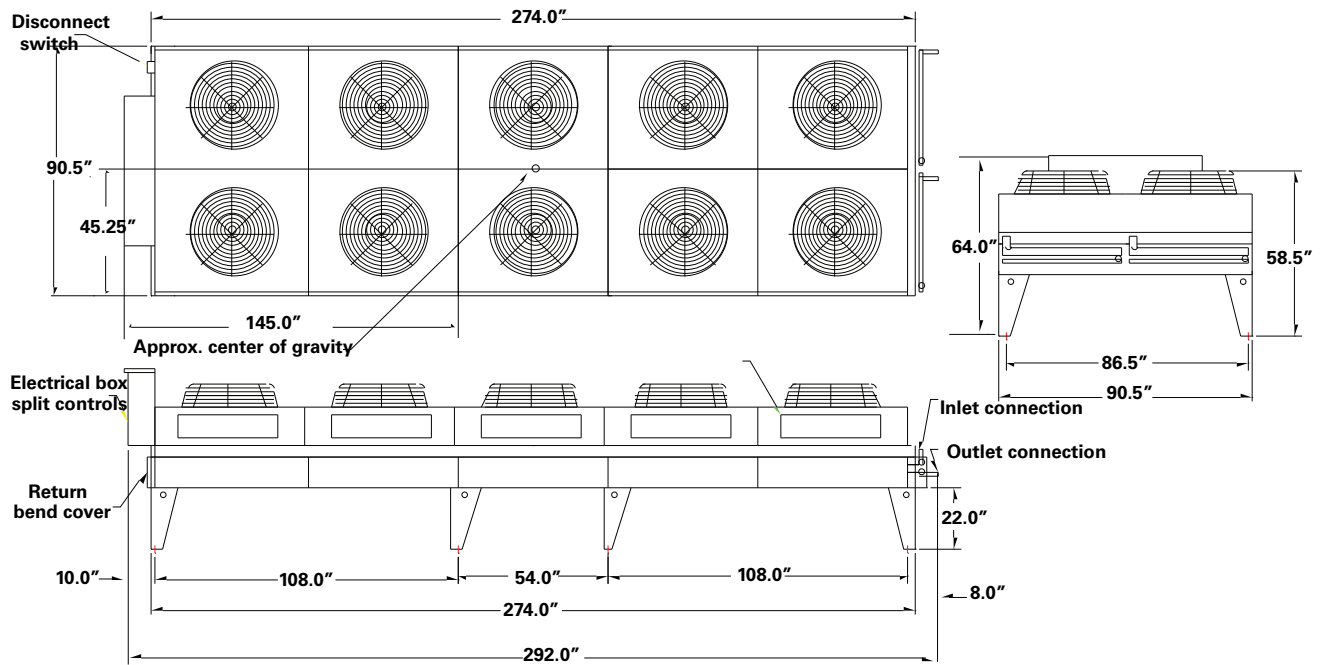

Figure 10. Air-cooled condenser — 120 and 130 ton (condenser 1 and 2)





Weights

RTWD

Table 46. Weights – RTWD, 60 Hz

Model	Standard Efficiency				High Efficiency				Premium Efficiency			
	Operating		Shipping		Operating		Shipping		Operating		Shipping	
	lb	kg	lb	kg	lb	kg	lb	kg	lb	kg	lb	kg
Standard Waterbox												
80	5900	2676	5703	2587	5732	2600	5551	2518	-	-	-	-
90	5933	2691	5721	2595	5792	2627	5587	2534	-	-	-	-
100	6140	2785	5902	2677	6255	2837	6025	2733	-	-	-	-
110	6332	2872	6074	2755	6475	2937	6208	2816	-	-	-	-
120	6530	2962	6248	2834	6510	2953	6230	2826	-	-	-	-
130	6535	2964	6244	2832	6543	2968	6248	2834	-	-	-	-
140	6971	3162	6649	3016	-	-	-	-	-	-	-	-
150	-	-	-	-	7884	3576	7544	3422	8724	3957	8243	3739
160	-	-	-	-	8395	3808	8036	3645	9171	4160	8691	3942
180	-	-	-	-	8490	3851	8098	3673	9290	4214	8772	3979
200	-	-	-	-	8578	3891	8157	3700	9337	4235	8803	3993
220	-	-	-	-	9493	4306	8995	4080	-	-	-	-
250	-	-	-	-	10071	4568	9478	4299	-	-	-	-
Marine Waterbox Option												
80	6215	2819	5873	2664	6047	2743	5719	2594	-	-	-	-
90	6248	2834	5891	2672	6107	2770	5754	2610	-	-	-	-
100	6455	2928	6073	2754	6574	2982	6193	2807	-	-	-	-
110	6645	3014	6241	2831	6790	3080	6378	2893	-	-	-	-
120	6845	3105	6418	2911	6828	3097	6398	2902	-	-	-	-
130	6850	3107	6413	2909	6859	3111	6418	2911	-	-	-	-
140	7289	3306	6819	3093	-	-	-	-	-	-	-	-
150	-	-	-	-	8356	3790	7780	3529	9196	4171	8477	3845
160	-	-	-	-	8867	4022	8270	3751	9643	4374	8924	4048
180	-	-	-	-	8962	4065	8331	3779	9762	4428	9008	4086
200	-	-	-	-	9050	4105	8391	3806	9808	4449	9037	4099
220	-	-	-	-	10020	4545	9259	4200	-	-	-	-
250	-	-	-	-	10595	4806	9744	4420	-	-	-	-

Note: Weights include optional base rail for fork lifting. Subtract 300 lbs (136.1 kg) if this option is not selected.

RTUD

Table 47. Weights – RTUD, 60 Hz

Model	Operating		Shipping	
	lb	kg	lb	kg
80	4874	2211	4793	2174
90	4892	2219	4804	2179
100	5073	2301	4974	2256
110	5326	2416	5221	2368
120	5322	2414	5194	2356
130	5322	2414	5194	2356
150	5917	2684	5781	2622
160	6804	3086	6643	3013
180	6876	3119	6715	3046
200	6980	3166	6810	3089
220	7300	3311	7112	3226
250	7602	3448	7401	3357

Note: Weights include optional base rail fork lifting, subtract 300 lbs (136.1 kg) if this option is not selected.

Air-Cooled Condenser

Table 48. Air-cooled condenser shipping weights

RTUD Size	Condenser 1		Condenser 2	
	lb	kg	lb	kg
80	2100	953	-	-
90	2651	1202	-	-
100	2884	1308	-	-
110	2950	1338	-	-
120	4005	1817	-	-
130	4046	1835	-	-
150	2044	927	2100	953
160	2100	953	2100	953
180	2100	953	2526	1146
200	2526	1146	2526	1146
220	2526	1146	2884	1308
250	2884	1308	2884	1308



Mechanical Specifications

General

Exposed metal surfaces are painted with air-dry beige, direct-to-metal, single-component paint. Each RTWD unit ships with full operating charges of refrigerant and oil. RTUD units ship with a full operating charge of oil and a nitrogen holding charge. Molded elastomeric isolation pads are supplied for placement under all support points.

Trane air-cooled condenser structural elements and fan sections are galvanized steel.

Compressor and Motor

The unit is equipped with two semi-hermetic, direct-drive, 3600 rpm 60 Hz rotary compressors that include a load/unload valve, rolling element bearings, oil filtration device and heater. The motor is a suction gas-cooled, hermetically sealed, two-pole squirrel cage induction motor. Oil separator device is provided separate from the compressor. Check valves in the compressor discharge and lube oil system and a solenoid valve in the lube system are also provided.

Unit-Mounted Starter

The unit is supplied with a UL 1995 indoor type enclosure with top power-wiring access and three-phase, overload protection. The starter is available in a wye-delta or across-the-line configuration, factory-mounted and fully pre-wired to the compressor motor and control panel. A factory-installed, factory-wired 820 VA control power transformer provides all unit control power (120 Vac secondary) and Trane CH530 module power (24 Vac secondary). Optional starter features include circuit breaker, high fault panel with circuit breaker, or mechanical, non-fused disconnect.

Evaporator

Dual circuited, shell and tube falling film evaporator design is used. Seamless internally finned, copper tubes are mechanically expanded into tube sheets and mechanically fastened to tube supports. Evaporator tubes are 1.0 inch (25.4 mm) diameter on standard efficiency chillers and 0.75 inch (19.05 mm) diameter on high and premium efficiency chillers. All tubes can be individually replaced.

Shells and tube sheets are made of carbon steel. Designed, tested, and stamped in accordance with ASME code. The evaporator is designed for refrigerant-side/working-side pressure of 200 psig (13.8 bars).

All water pass arrangements are available with grooved connections with 150 psig (1010.5 bars) waterside working pressure. Waterside shall be hydrostatically tested at 225 psig (14.515.5 bars).

Condenser (RTWD only)

Dual circuited, shell and tube condenser designed with seamless internally/externally finned tubes expanded into tube sheets and mechanically fastened to tube supports. Condenser tubes are 1.0 inch (25.4 mm) diameter on standard efficiency chillers and 0.75 inch (19.05 mm) diameter on high and premium efficiency chillers. All tubes can be individually replaced.

Shells and tube sheets are made of carbon steel. Designed, tested, and stamped in accordance with ASME code. The condenser is designed for refrigerant-side/working-side pressure of 300 psig (20.7 bars).

Water side has single inlet and outlet piping connection. All water pass arrangements are available with grooved connections with 150 psig (10.5 bars) waterside working pressure. Waterside shall be hydrostatically tested at 225 psig (15.5 bars).

Standard temperature condenser allows for leaving condenser water temperature up to 105°F (40.6°C) and for entering condenser water temperatures up to 95°F (35°C).

Condenser (Trane air-cooled only)

Air-cooled condenser coils have aluminum fins mechanically bonded to internally finned seamless copper tubing. The condenser coil has a subcooling circuit. Condensers are factory proof and leak tested at 400 psig (27.6 bars).

Direct-drive vertical discharge condenser fans are balanced. Three-phased condenser fan motors with permanently lubricated ball bearings and inherent overheat protection in each phase are provided.

Standard ambient units start and operate from 32°F to 125°F (0°C to 52°C).

Refrigerant Circuit

Each unit has two refrigerant circuits, with one rotary screw compressor per circuit. Each refrigerant circuit includes compressor suction and discharge service valves, removable core filter, charging port, sight glass and an electronic expansion valve. Modulating compressors and electronic expansion valves provide variable capacity modulation over the entire building load and maintain proper refrigerant flow. The RTWD also includes liquid line isolation valves and refrigerant pressure relief valves installed on each circuit of both the evaporator and condenser.

For RTUD each refrigerant circuit also includes oil separator, oil cooler, and liquid line service valve (NOT isolation valve), and refrigerant pressure relief valve installed on each circuit of the evaporator (for the low side) and on each oil separator (for the high side). The discharge line leaving the oil separator and liquid line entering the filters are capped and brazed.

Oil Management

The unit is configured with an oil management system that ensures proper oil circulation throughout the unit. The key components of the system include an oil separator, oil filter and gas pump. An optional oil cooler is installed when the unit is used for high condensing temperature or low evaporator temperature conditions. For example: remote condensers, heat recovery, water-to-water heat pump, ice making and low temperature process applications.

Unit Controls (Trane CH530)

The microprocessor-based control panel is factory-installed and factory-tested. The control system is powered by a pre-wired control power transformer, and will load and unload the chiller through adjustment of the compressor slide valve. Microprocessor-based chilled water reset based on return water is standard.

The Trane CH530 microprocessor automatically acts to prevent unit shutdown due to abnormal operating conditions associated with low evaporator refrigerant temperature, high condensing temperature, and/or motor current overload. If an abnormal operating condition continues and the protective limit is reached, the machine will shut down.

The panel includes machine protection shutdown requiring *manual reset* for the following conditions:

- Low evaporator refrigerant temperature and pressure
- High condenser refrigerant pressure
- Low oil flow
- Critical sensor or detection circuit faults
- Motor current overload
- High compressor discharge temperature
- Lost communication between modules



Mechanical Specifications

- Electrical distribution faults: phase loss, phase imbalance, or phase reversal
- External and local emergency stop
- Starter transition failure

The panel also includes machine protection shutdown with *automatic reset* for the following correctable conditions:

- Momentary power loss
- Under/over voltage
- Loss of evaporator or condenser water flow

When a fault is detected, the control system conducts more than 100 diagnostic checks and displays results. The display will identify the fault, indicate date, time, and operating mode at time of occurrence, and provide type of reset required and a help message.

Clear Language Display Panel

Factory-mounted to the control panel door, the operator interface has an LCD touch-screen display for operator input and information output. This interface provides access to the following information: evaporator report, condenser report, compressor report, ASHRAE Guideline 3 report, operator settings, service settings, service tests, and diagnostics. All diagnostics and messages are displayed in clear un-coded language.

Data contained in available reports includes:

- Water and air temperatures
- Refrigerant levels and temperatures
- Oil pressure
- Flow switch status
- EXV position
- Head pressure control command
- Compressor starts and run-time
- Line phase percent RLA, amps, and volts

All necessary settings and setpoints are programmed into the microprocessor-based controller via the operator interface. The controller is capable of receiving signals simultaneously from a variety of control sources, in any combination, and priority order of control sources can be programmed. The control source with priority determines active setpoints via the signal it sends to the control panel. Control sources may be:

- Local operator interface (standard)
- Time of day scheduling (optional capability available from local operator interface)
- Hard-wired 4-20 mA or 2-10 Vdc signal from an external source (interface optional; control source not supplied)
- LonTalk® LCI-C (interface optional; control source not supplied)
- BACnet® BCI-C (interface optional; control source not supplied)
- Trane Tracer® Summit system (interface optional; control source not supplied)

Quality Assurance

The quality management system applied by Trane has been subject to independent third-party assessment and approval to ISO 9001. The products described in this catalog are designed, manufactured and tested in accordance with the approved system requirements described in the Trane Quality Manual.

Electrical Options

Across-the-Line Starter

Across-the-line starter is unit mounted with a UL 1995 enclosure.

Wye-Delta Starter

This option provides a reduced-inrush, unit mounted starter with a UL 1995 enclosure. Wye-delta starters are standard with 200–230 V machines.

Circuit Breaker

A molded case standard interrupting capacity circuit breaker, factory pre-wired with terminal block power connections and equipped with a lockable external operator handle, is available to disconnect the chiller from main power.

High Fault Rated Control Panel with Circuit Breaker

A molded case circuit breaker, factory pre-wired with terminal block power connections and equipped with a lockable external operator handle, is available to disconnect the chiller from main power. The control panel has a higher short circuit rating as determined by UL 508.

Non-Fused Disconnect

A non-fused molded case disconnect switch, factory pre-wired with terminal block power connections and equipped with a lockable external operator handle, is available to disconnect the chiller from main power.

Dual Point Power Connection

Unit is available with either dual or single point power connections.

Under/Over-Voltage Protection

Unit receives protection against variations in voltage (current lag and spike protection is standard).



Mechanical Specifications

Control Options

A/C Fan Control (RTUD only)

Fan controls are integral to the chiller panel and shall manage the appropriate relays and variable speed fan outputs to control the differential pressure.

BACnet Interface

BACnet® communications capabilities are available, with communication link via single twisted-pair wiring to communication board.

Chilled Water Reset – Outdoor Air Temperature

Controls, sensors, and safeties allow reset of chilled water temperature, based on temperature signal, during periods of low outdoor air temperature (chilled water reset based on return chilled water temperature is standard). Standard for RTUD units.

Condenser Leaving Water Temperature Control (RTWD only)

Enables the unit to use the leaving condenser water temperature to load and unload the chiller relative to the leaving condenser water setpoint. The control system allows for a condenser leaving temperature range of 80°F (26.7°C) to 140°F (60°C) with a water to water heat pump.

Condenser Differential Pressure Output (RTWD only)

Provides a 2–10 Vdc signal based on the system refrigerant differential pressure and time at the differential with customer defined endpoints.

Condenser Water Control Output (RTWD only)

Provides a highly configured signal designed to control a condenser water regulating valve.

External Chilled Water or Hot Water Setpoint

External chilled or hot water setpoint signal can be field wired to a factory-installed, tested interface board through a 2–10 Vdc or 4–20 mA signal.

External Current-Limiting

External current-limit setpoint is communicated to a factory-installed, tested communication board through a 2–10 Vdc or 4–20 mA signal.

LonTalk/Tracer Summit Interface

LonTalk® (LCI-C) or Tracer Summit® communications capabilities are available, with communication link via single twisted-pair wiring to factory-installed, tested communication board.

Low Ambient Fan Control - Two Speed (RTUD only)

The fan control shall provide for the first fan to be a two speed fan and the microprocessor can be programmed to control the low and high speed of that fan.

Low Ambient Fan Control - Variable Speed (RTUD only)

The fan control shall operate a fixed speed fan or a single inverter driven fan and the controls include the enabling and speed command signals to the variable speed inverter.

Motor Current Analog Output

Control system indicates the active chiller percent of full run load amps, based on a 2–10 Vdc.

Power Meter

Tracks energy consumption (compressors only) with kWh meter.

Programmable Relays

Predefined, factory-installed, programmable relays allow the operator to select four relay outputs. Available outputs are: Alarm-Latching, Alarm-Auto Reset, General Alarm, Warning, Chiller Limit Mode, Compressor Running, Head Pressure Relief Request, and Tracer Control.

Time of Day Scheduling

Time of day scheduling capabilities are available for scheduling single chiller applications through Trane CH530 panel (without the need for building automation system-BAS). This feature allows the user to set up to 10 events in a 7 day time period.

Trane Air-Cooled Remote Condenser Options (RTUD only)

Low Ambient

Allows the condenser to start and operate down to 14°F and up to 125°F (-10°C-52°C).

Condenser Voltage

Voltages available 208-230, 460, and 575.

CompleteCoat Condenser Coil

Allows for the operation in coastal environments. This option includes condenser coil box coating that resists bi-metallic corrosion.



Mechanical Specifications

Other Options

Base Rail Forklifting

Channels built into the base frame allow for easy movement using a forklift.

Condenser Marine Waterboxes

Marine waterboxes for the condenser allow tube cleaning without water pipe interference.

Dual Relief Valve

Unit comes with dual relief valves on both the high pressure side and low pressure side of each refrigerant circuit. Each dual relief valve configuration includes an isolation valve. Single relief valves are standard.

Flanged Water Connection Kit

Kit to convert all four water connections (RTWD units) or two water connections (RTUD units) from grooved pipe to flanged connections. This includes: grooved couplings, pipe offsets, and grooved to flange adapters.

Flow Switches - Factory Installed

Factory installed IFM effector flow switches for the evaporator and/or condenser.

Flow Switches - Field Installed

NEMA 1 or NEMA 4 150 psi flow switches ship with the unit.

High-Temperature Condenser

Optimized compressors, oil cooler and high condenser temperature control panel allows for leaving condenser water temperatures up to 140°F (60°C). This option is required for entering condenser water temperatures above 95°F (35°C).

Insulation

The evaporator, water boxes, and motor housing are covered with factory installed 0.75 inch (19.05 mm) insulation. Factory installed foam insulation is used on the suction line, liquid level sensor, oil return system assembly (with its associated piping).

Insulation for High Humidity

The evaporator and water boxes are covered with factory installed 1.5 inch (38.1 mm) insulation. Factory installed foam insulation is used on the motor housing, suction line, liquid level sensor, and oil return system assembly (with its associated piping).

Isolators

Molded elastomeric isolators ship with the unit.

Low-Temperature Evaporator

Optimized compressors and oil cooler enable evaporator operation down to minimum leaving water temperature of 10°F (-12.2°C).

Nitrogen Charge

Unit is shipped with a nitrogen holding charge in lieu of refrigerant (standard for RTUD).

Performance Tests

Performance and witness tests are available, based on requested operating points, to certify chiller performance in accordance with AHRI Standard 550/590.

Rapid Restart™ Test

After completion of a standard full load witness test, power to the chiller will be cut and then reapplied to demonstrate the chiller's rapid restart capabilities for disaster relief.

Two-Way Condenser Water Regulating Valve (RTWD only)

For water regulation, a field-installed, 2-way butterfly-type (lug-style) valve and field-mounted valve actuator, is available. The 2-way valve is field-wired and controlled by the chiller regulating valve control output. The single-phase, dual frequency, 50 or 60 Hz, motor can be selected with 115V (can be powered directly from control power transformer at unit) or 220V power.

Note: Separate 220 volt power must be field supplied for 220V water regulating valve option.

Valves are available in 3 and 4 inch (88.9 mm and 114.3 mm) sizes.

Seismic Rating - IBC

The unit is built and certified for seismic applications in accordance with the following International Building Code (IBC) releases 2000, 2003, 2006 and 2009.

Seismic Rating - OSHPD

The unit is built and certified for seismic applications in accordance with OSHPD. The unit is factory modified with reinforced steel anchors welded to the base.

Sound Reduction Package

Acoustical treatment for compressors can be factory or field installed.

Water-to-Water Heat Pump

Optimized compressors, oil cooler and high condenser temperature control panel allows for leaving condenser water temperatures up to 140°F (60°C). This option allows for entering condenser water temperatures above 95°F (35°C). Condenser leaving water temperature control option is required; the setpoint range is 80°F (26.7°C) to 140°F (60°C).



Trane optimizes the performance of homes and buildings around the world. A business of Ingersoll Rand, the leader in creating and sustaining safe, comfortable and energy efficient environments, Trane offers a broad portfolio of advanced controls and HVAC systems, comprehensive building services, and parts. For more information, visit www.Trane.com.

Trane has a policy of continuous product and product data improvement and reserves the right to change design and specifications without notice.